



stratasys

F123 Series Shared Office 3D Printers

OPERATION AND MAINTENANCE GUIDE

Part No. DOC-10001_REV_A



LIABILITY STATEMENT

The information in this document is subject to change without notice. Stratasys, Inc. shall not be liable for errors contained herein or for incidental or consequential damages in connection with the furnishing, performance, or use of this material. Stratasys, Inc. makes no warranty of any kind with regard to this material, including, but not limited to, the implied warranties of merchantability and fitness for a particular purpose. It is the responsibility of the system owner/ material buyer to determine that the Stratasys material is safe, lawful, and technically suitable for the intended application as well as identify the proper disposal (or recycling) method consistent with local environmental regulations. Except as provided in Stratasys' standard conditions of sale, Stratasys shall not be responsible for any loss resulting from any use of its products described herein.

COPYRIGHT STATEMENT

© Copyright 2017 Stratasys Inc. All rights reserved. This document is protected by copyright. No part of this document may be photocopied, reproduced or translated into another language without the prior written consent of Stratasys, Inc. All drawings and information herein are the property of Stratasys Inc. All unauthorized use and reproduction is prohibited.

TRADEMARK ACKNOWLEDGMENTS

Stratasys, F123 Series, F170, F270, F370, Insight, GrabCAD and FDM are trademarks of Stratasys Ltd. and/or subsidiaries or affiliates and may be registered in certain jurisdictions. All other product names and trademarks are the property of their respective owners.

DECLARATION OF CONFORMITY

Declaration of Conformity information is available from the Stratasys website at: <http://www.stratasys.com/customer-support/customer-resource-center/documentation>.

EMC CLASS A WARNING



Warning: This is a Class A product. In a domestic environment this product may cause radio interference in which case the user may be required to take adequate measures.

MSDS (MATERIAL SAFETY DATA SHEET)

You can obtain current Material Safety Data Sheets for the material used in the printer is available at: <http://www.stratasys.com/materials/material-safety-data-sheets>.

DISPOSAL OF WASTE EQUIPMENT BY USERS IN PRIVATE HOUSEHOLDS IN THE EUROPEAN UNION



This symbol on the product or on its packaging indicates that this product must not be disposed of with your other household waste. Instead, it is your responsibility to dispose of your waste equipment by handing it over to a designated collection point for the recycling of waste electrical and electronic equipment. The separate collection and recycling of your waste equipment at the time of disposal will help to conserve natural resources and ensure that it is recycled in a manner that protects human health and the environment. For more information about where you can drop off your waste equipment for recycling, please contact your local city office, your household waste disposal service or the shop where you purchased the product.

REVISION LOG

Revision	Date	Description of Changes
DOC-10001_REV_A	August 2017	Initial release.

TABLE OF CONTENTS

ABOUT THIS GUIDE	1
F123 SERIES PRINTER	1
PRINTER COMPONENTS	2
Access Doors and Panels.....	2
Interface Panel.....	4
Oven Components.....	5
Material Bay Drawer Components.....	11
Gantry Components.....	15
MODEL TAGS.....	17
REAR CONNECTIONS.....	18
AVAILABLE MATERIALS.....	19
MINIMUM CLEARANCES.....	19
OPERATING ENVIRONMENT.....	19
Safe Environment.....	19
Environmental Requirements.....	19
TOOLS/WELCOME KIT CONTENTS.....	20
SAFETY INFORMATION	24
HAZARD TYPES.....	24
SAFETY SYMBOLS	24
Oven Safety Label Locations.....	25
Rear Safety Label Locations.....	26
Electrical Panel Safety Label Locations.....	26
SAFETY PRECAUTIONS	27
Oven.....	27
Gantry.....	27
Z Stage.....	27
DOOR LOCKS	27
STABILITY PADS.....	28
GENERAL SAFETY PRACTICES.....	28

BASIC USER OPERATIONS	29
POWERING ON THE PRINTER	29
POWERING OFF THE PRINTER	30
CONFIGURING THE NETWORK	31
USER INTERFACE	36
Navigation Menu	37
Display Area	38
Build Page	38
Queue Page	46
Materials Page	56
Tools Page	57
MATERIAL HANDLING	59
Loading Material	59
Unloading Material	63
Material Auto Changeover	65
Storing Materials	66
CHANGING HEADS	67
Replacing a Standard Head	67
Replacing a PLA Head	68
TIP CALIBRATION	69
BASIC JOB BUILD TASKS	71
Before a Build	71
Preparing the Printer	71
Selecting a Job to Build	72
Information Available During a Build	73
Build Warnings	74
Pausing a Build	75
Aborting a Build	76
After a Build is Complete	78
Removing a Part from the Printer	79



USER MAINTENANCE	80
WEEKLY MAINTENANCE	81
Cleaning the Oven Chamber	81
Cleaning the Platen	81
MONTHLY MAINTENANCE.....	82
Clean/Inspect Tip Wipe Assemblies	82
AS NEEDED MAINTENANCE	84
Cleaning the Exterior Surface of the Printer	84
Cleaning the Touchscreen Display	84

ABOUT THIS GUIDE

This guide provides basic instructions for the F123 Series printer. Instructions and specifications pertain to the F170, F270 or F370 models, unless otherwise stated. For additional information, contact your Stratasys representative.

F123 SERIES PRINTER

The Stratasys F123 Series 3D printers incorporate the latest in innovative technology to provide you with precise prototypes from a CAD design. Stratasys' Fused Deposition Modeling (FDM) technology provides prototype parts, including internal features, that can be used to field-test form, fit, and function. Direct Digital Manufacturing (DDM) allows for the creation of customized end-use parts straight from 3D CAD data. The F123 Series printers feature a servo/belt driven XY gantry with multiple modeling material capability.

F170 Highlights

- Envelope Size: 10 x 10 x 10 inch (254 x 254 x 254 mm)
- Material Bays: 1 model, 1 support
- Touchscreen Graphical User Interface
- Wi-Fi capabilities
- Three USB ports (2 in front, 1 in back)
- Camera for remote monitoring

F270 Highlights

- Envelope Size: 12 x 10 x 12 inch (308 x 254 x 308 mm)
- Material Bays: 2 model, 2 support
- Touchscreen Graphical User Interface
- Auto changeover capabilities
- Wi-Fi capabilities
- Three USB ports (2 in front, 1 in back)
- Camera for remote monitoring

F370 Highlights

- Envelope Size: 14 x 10 x 14 inch (356 x 254 x 356 mm)
- Material Bays: 2 model, 2 support
- Insight Software Package
- Touchscreen Graphical User Interface
- Auto changeover capabilities
- Wi-Fi capabilities
- Three USB ports (2 in front, 1 in back)
- Camera for remote monitoring

PRINTER COMPONENTS

- The F123 Series Printer
- Material Package(s)
- Welcome Kit (containing documentation on how to download your user guide and common tools for maintaining the printer)
- GrabCAD Print Software Package
- A Computer Workstation (not sold by Stratasys)

ACCESS DOORS AND PANELS



Warning: Do not energize when the rear panel is not secured in place.

This printer has been designed to allow easy access to the most frequently accessed areas on the system.

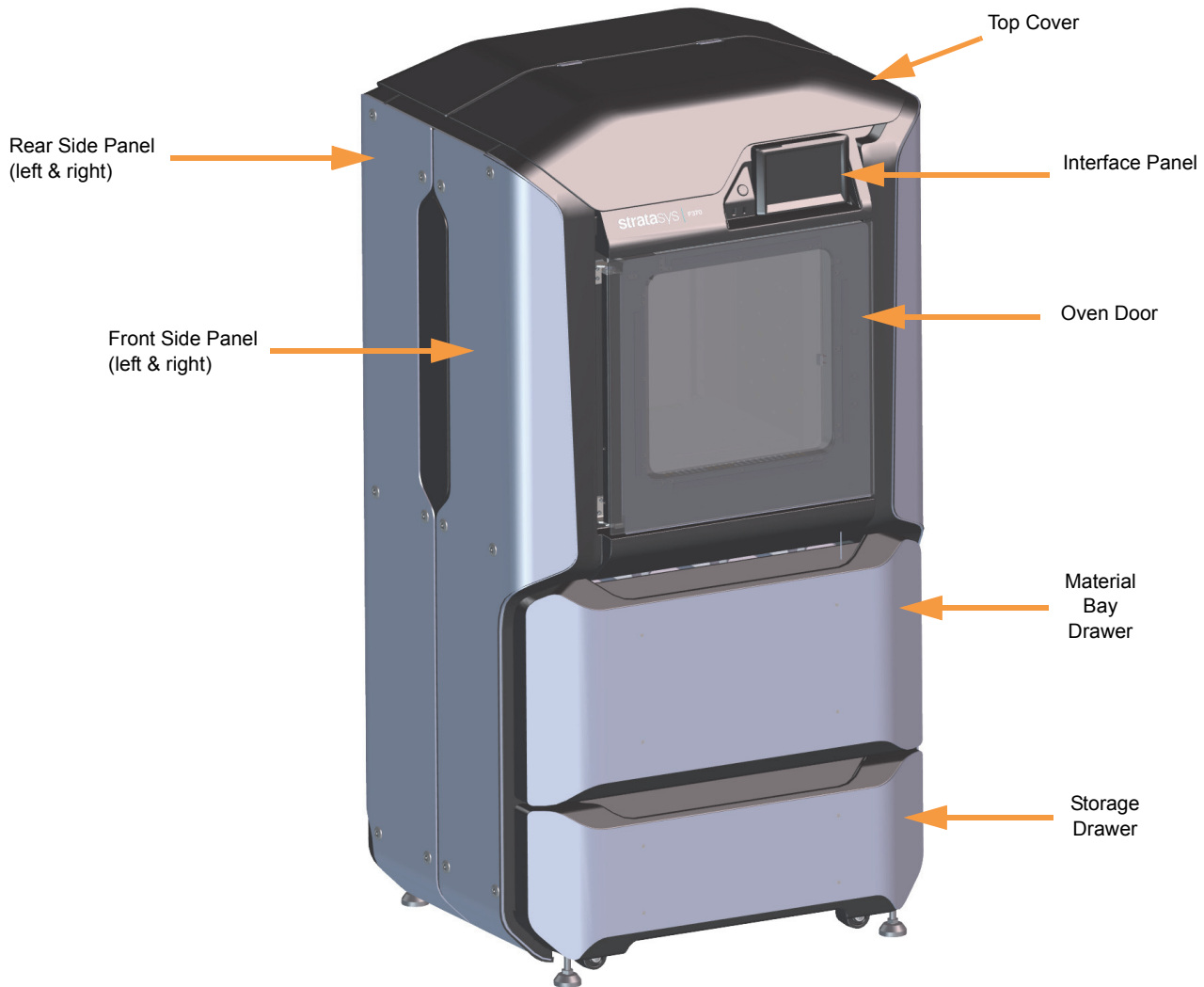

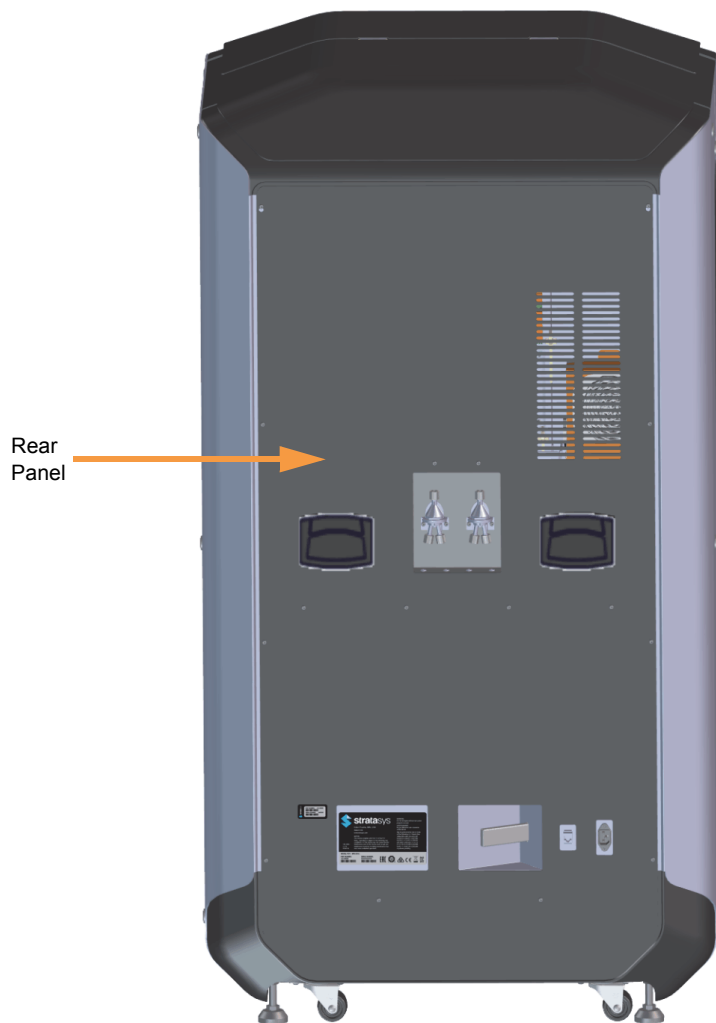

TOP COVER

Allows access to the gantry and head assemblies.

OVEN DOOR

Allows access to the platen, tip wipe assemblies, purge area, and completed parts for removal. The printer's camera is also housed within the oven door.

MATERIAL BAY DRAWER

Allows access to the material bay components (material bays, material spools, and the material drive controllers).

STORAGE DRAWER

Provides a built-in area which can be used for miscellaneous storage of spare parts, tools, etc., as needed.

RIGHT & LEFT SIDE PANELS

The right and left side panels provide access to the oven chamber fans.

REAR PANEL

The rear panel provides access to the electronics bay.

INTERFACE PANEL

The interface panel houses the printer's touchscreen user interface, power button, and USB ports.

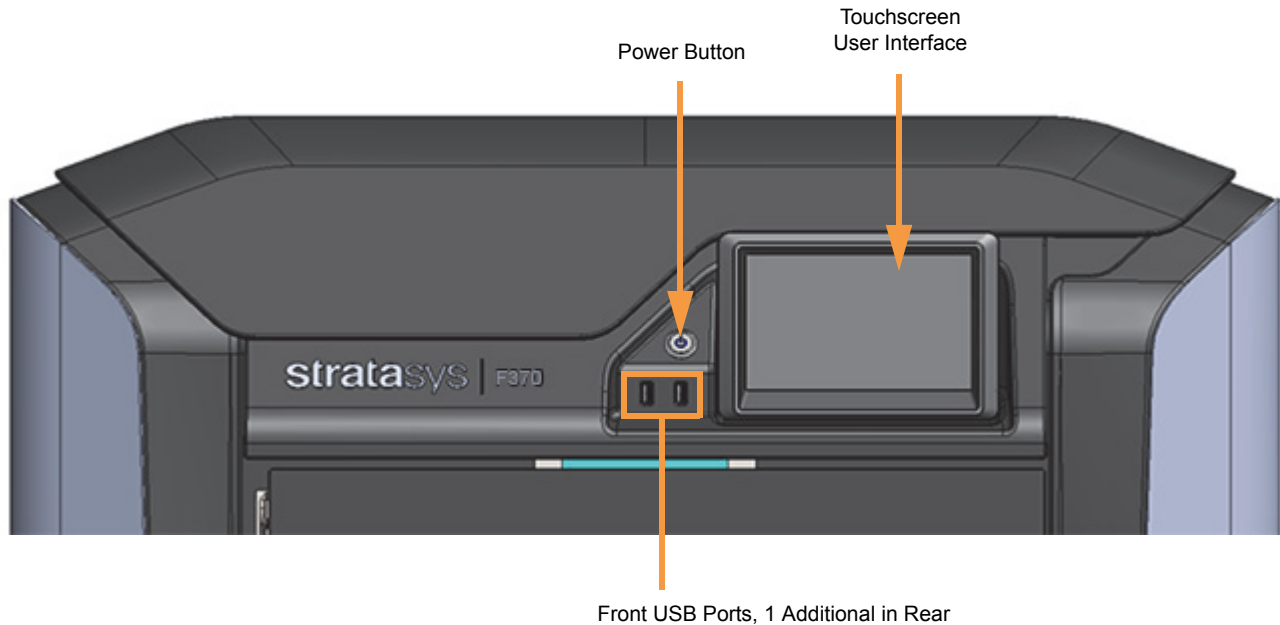

TOUCHSCREEN USER INTERFACE

Allows for user control of the printer. From the User Interface you can access various screens to select jobs for building, control jobs in the process of being built, change materials, perform calibrations, and configure your printer's settings and maintenance options. The touchscreen visually displays the operational state of the printer as well as any warning information available.

POWER BUTTON

Allows you to power the printer ON and OFF.

USB PORTS

The printer's USB ports allow you to easily upload job files to be built. After plugging a USB flash drive into any of the USB ports you can access the flash drive's contents via the Queue page.

OVEN COMPONENTS

The oven consists of the oven door and everything that you see through the oven door window, including the platen, tip wipe assemblies, purge chute, and oven heaters. The printer's camera is housed within the frame of the oven door.

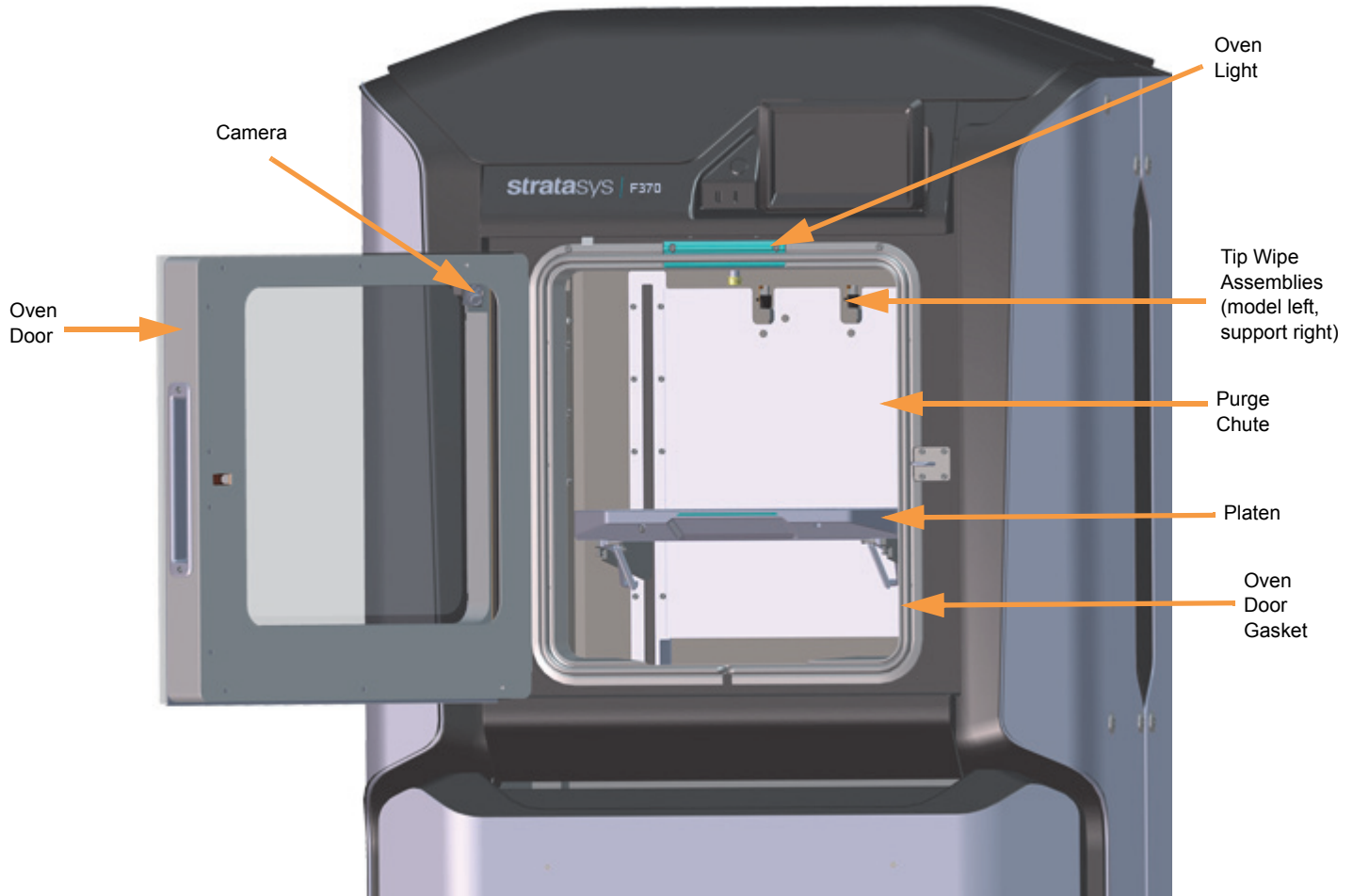

OVEN DOOR

The oven door utilizes an electromagnetic lock along with optical sensors. The oven door remains locked while the printer is building and automatically unlocks when it is safe for you to access the components of the oven. You cannot open the oven door when the printer is building. The top cover will automatically unlock in conjunction with the oven door, allowing you to manually open the top cover. The oven door must be open prior to opening the top cover. The oven door gasket, which runs around the perimeter of the oven door frame, helps to provide an airtight seal when the oven door is closed. The oven door window is composed of 2 panes of tempered glass.

CAMERA

The printer's camera is housed within the frame of the oven door and provides remote monitoring capabilities while a part is building. Using the GrabCAD Print application installed on your workstation PC, you can view the part as it is building allowing you to remotely monitor part build quality. Pictures are automatically taken at a set interval via GrabCAD Print. Please note that the camera image displayed will include some reflection as a result of the oven door's glass.

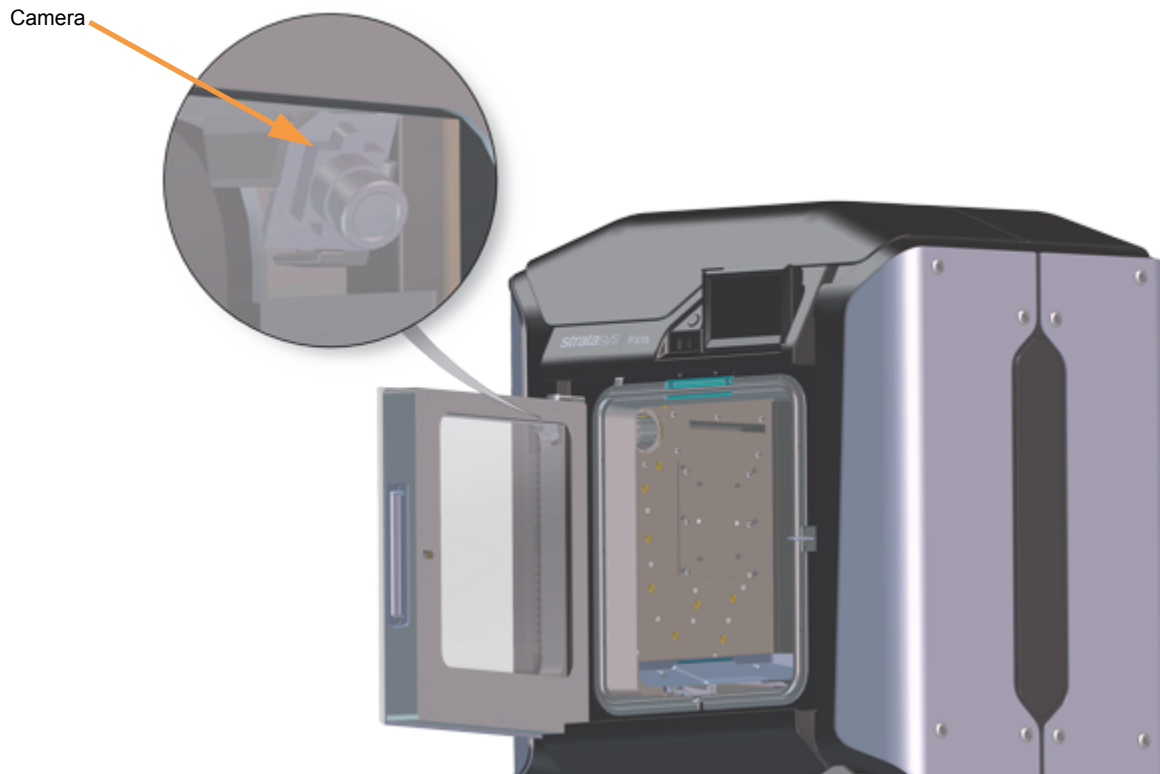

OVEN LIGHT

A single light pipe is mounted on the front upper edge of the oven and is used to illuminate the oven chamber. The light pipe consists of nine high-temperature LEDs; each LED is rated at 1-watt. The oven light is powered by 12 VDC.

The Light button within the Tools page indicates the current state of the oven light and allows you to manually turn the light ON or OFF.

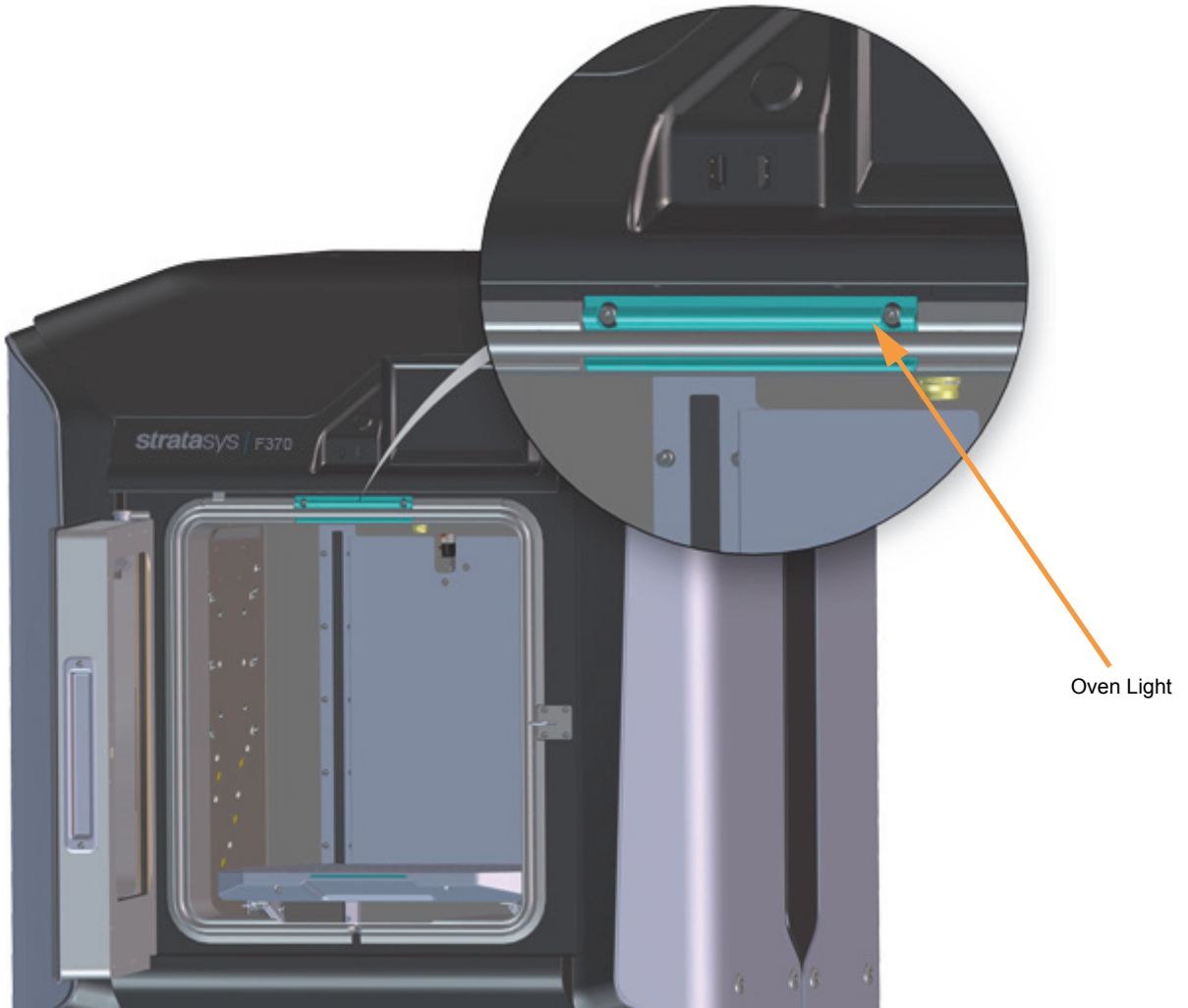

PLATEN

The steel platen provides the level surface on which parts are built. A substrate is securely affixed to the platen using the substrate ejection handle. After placing a substrate on the platen lifting up on the handle will lock the substrate into its build position; pressing down on the handle will release the substrate from the platen for removal.

The tip offset calibration targets are located on the rear center portion of the platen. These targets are used when determining the X and Y offset between model and support tips after either head has been replaced (during an automatic Tip Offset Calibration).

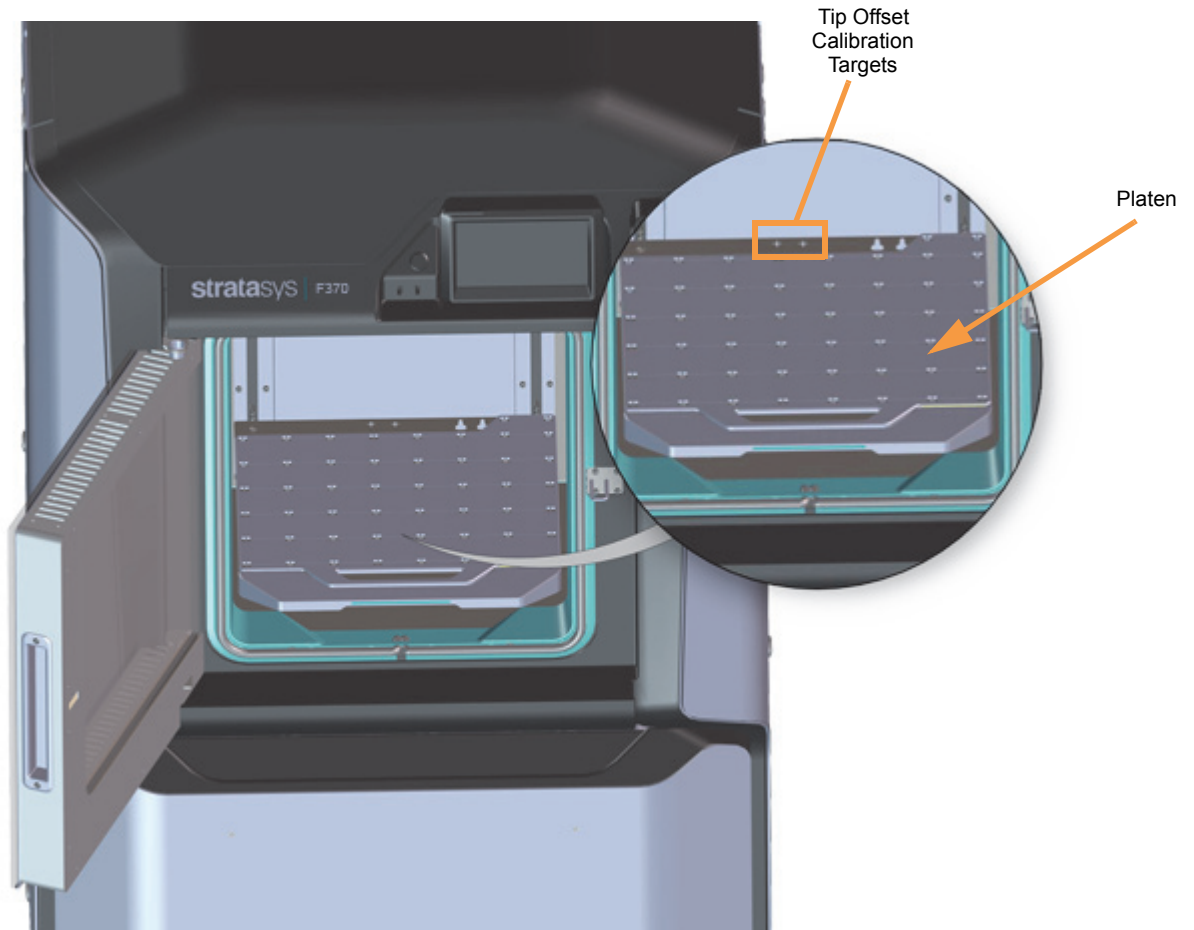

TIP WIPE ASSEMBLIES

Two tip wipe assemblies are located in the rear of the oven, one for model and one for support. Each assembly consists of a flicker and a brush. The tip wipe assemblies keep the printer's tips and tip shields free of purged material debris and material buildup. The tip wipe assemblies are mounted behind the purge chute and extend through the purge chute via two slots cut into the chute's exterior.

After material is purged from a tip, the tip passes across the tip wipe assembly. The flicker cuts the purged material from the end of the tip and knocks it into the purge chute. The brush cleans the tip and tip shield. Purged material debris is guided down from the tip wipe assemblies to the bottom of the oven chamber via the purge chute.

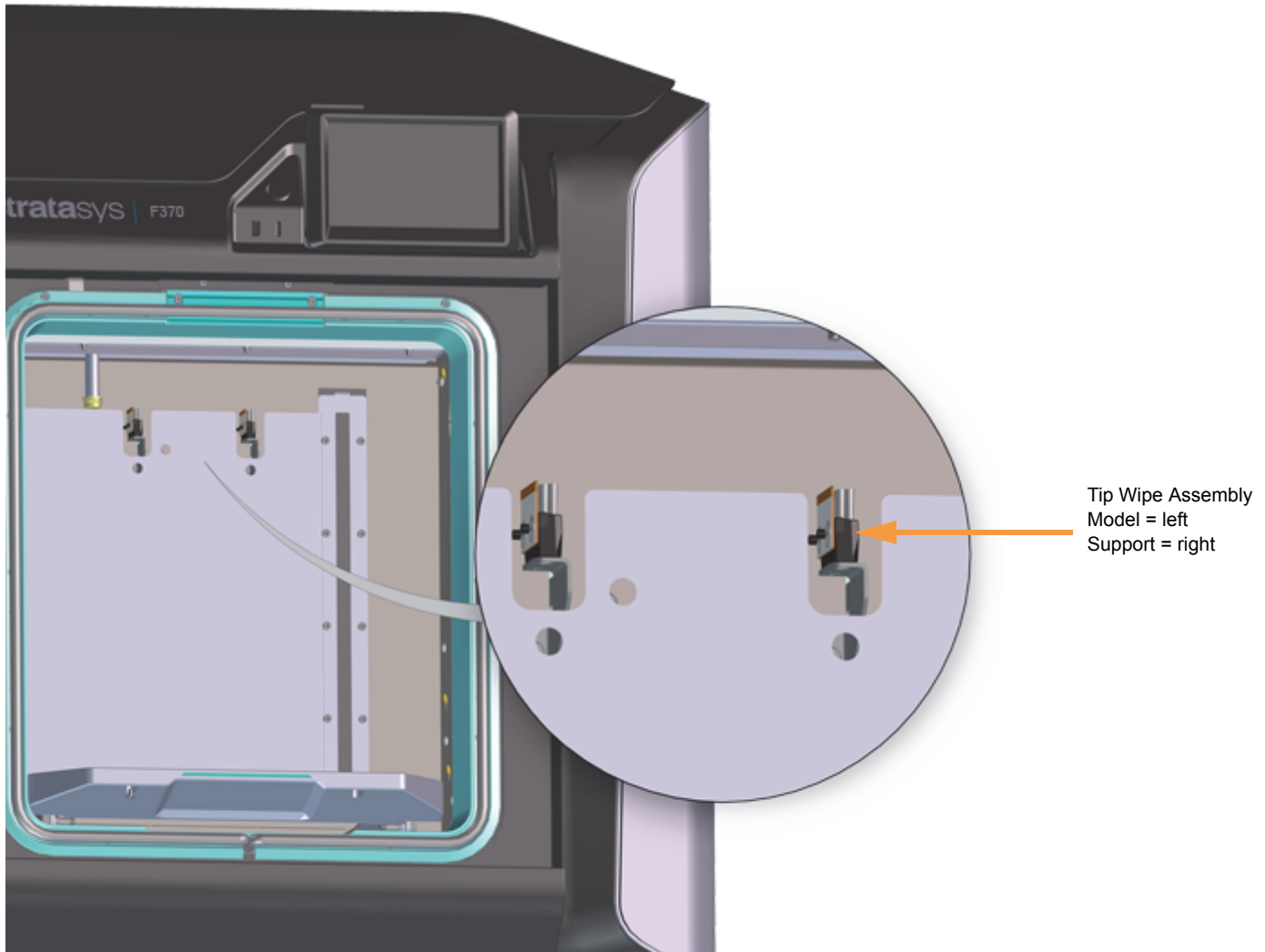

PURGE CHUTE

The purge chute is located in the back of the oven. Purged material debris is guided down from the tip wipe assemblies to the bottom of the oven chamber via the purge chute. Material debris exits the purge chute via an opening at the bottom of the chute and then accumulates in the bottom of the oven chamber. Accumulated material debris should always be cleaned on a weekly basis, or as needed if excessive accumulation occurs.

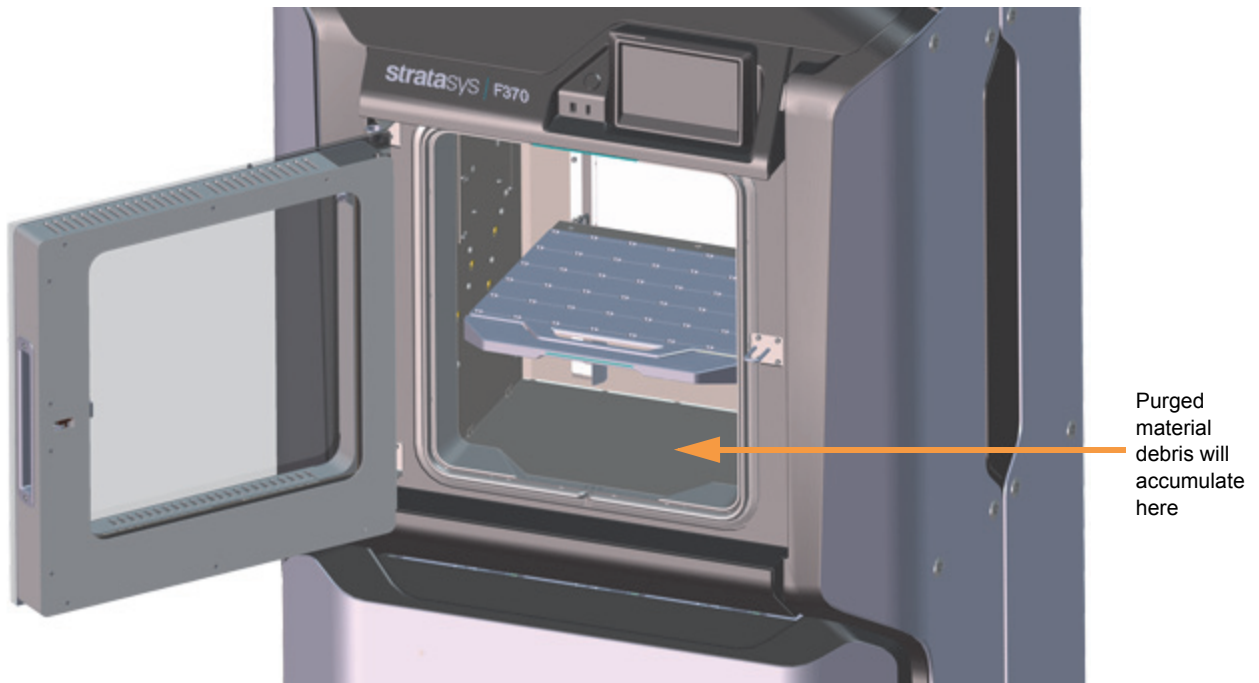
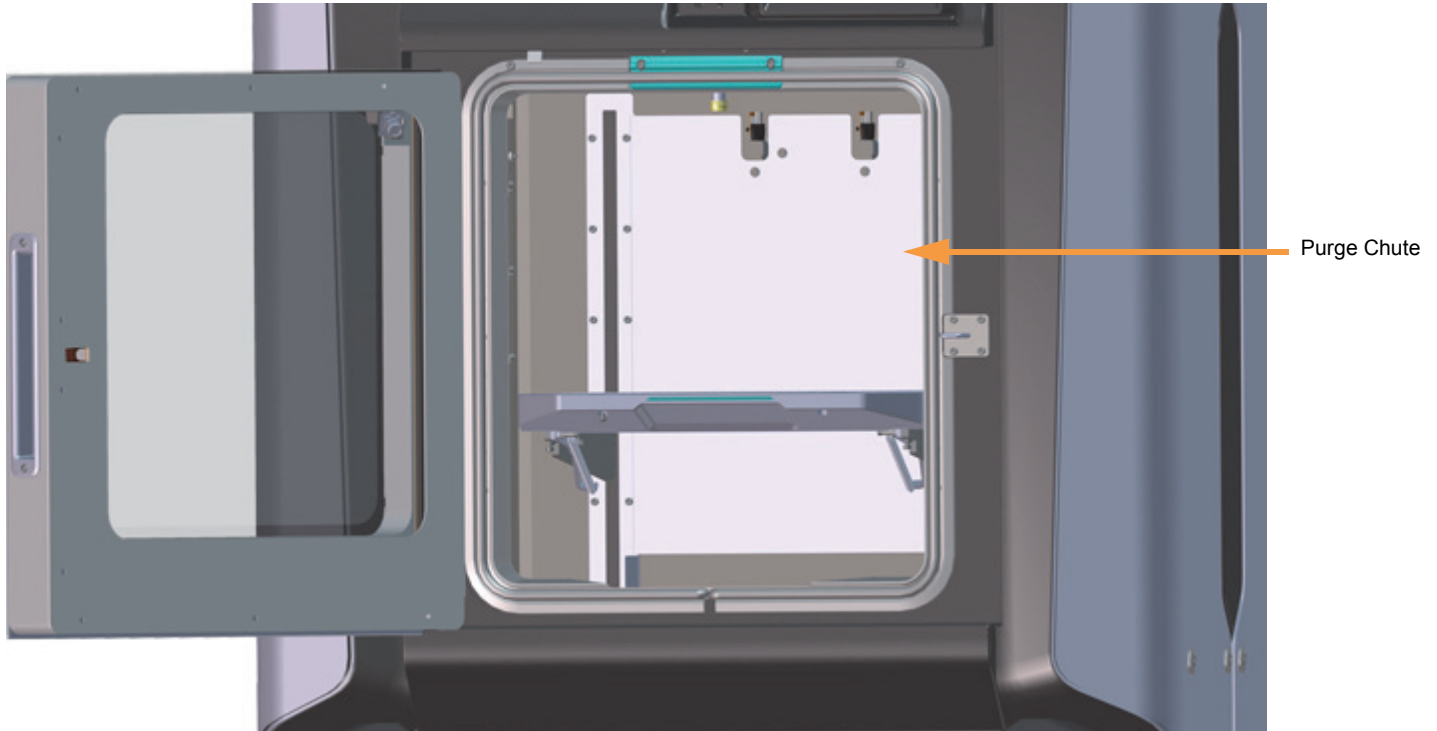

MATERIAL BAY DRAWER COMPONENTS

The model and support material bays are accessible by opening the material bay drawer on the front of the printer. The material bay drawer does not contain any locking mechanisms and can be opened while the printer is building.

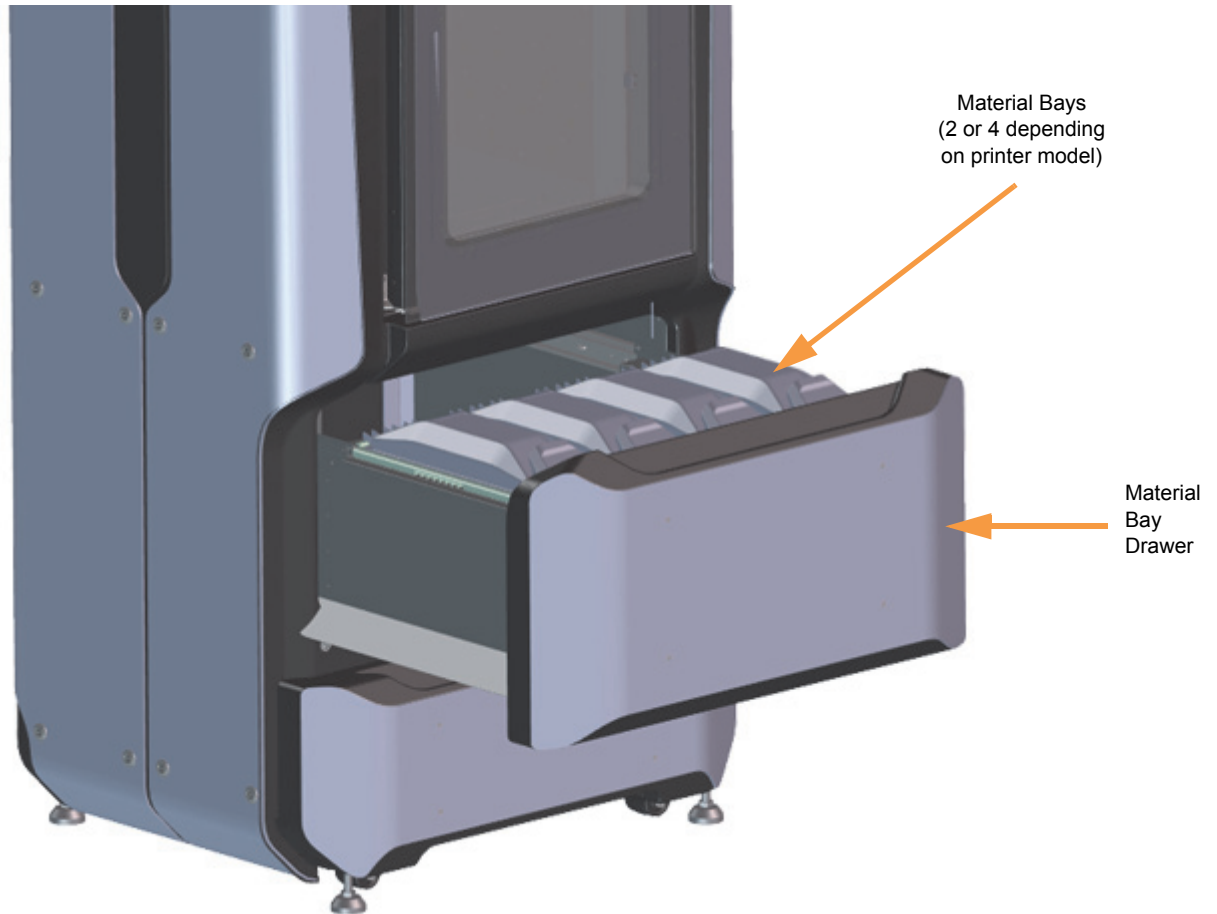

MATERIAL BAYS

The F270 and F370 printers have four operating material bays - two model and two support. The two left-most bays hold model material while the two right-most bays hold support material. The F170 printer has two operating material bays - one model and one support. The left bay holds model material while the right bay holds support material.

While building, one model and one support spool will be active. An active spool has material filament loaded to the head, as indicated by a solid blue pathway between the Material Status Icon and corresponding Head Status Icon, a solid blue Head Status Icon, and a solid blue border around the Material Status Icon on the touchscreen display. For applicable printer models, you can replace inactive spools without pausing the printer.



Note: The auto changeover capability automatically loads a second spool during a build when the first spool runs out of material. Auto changeover is only applicable for the F270 and F370 printers.

MATERIAL DRIVE CONTROLLER

Each individual material bay has a material drive controller. The material drive controller feeds filament from a material bay to the head. The material drive controller is located on the back side of the material bay and contains a small 12 VDC motor which drives filament up to the head. The material drive controller is a non-serviceable item and is instead replaced along with the replacement of a material bay.

The material drive controller contains a mechanical filament present switch which detects the presence of material within the material drive during the load and unload process. This switch also detects errors. If the material drive controller detects that filament has broken within the material bay or the end of filament is reached, the printer will pause to allow for recovery.

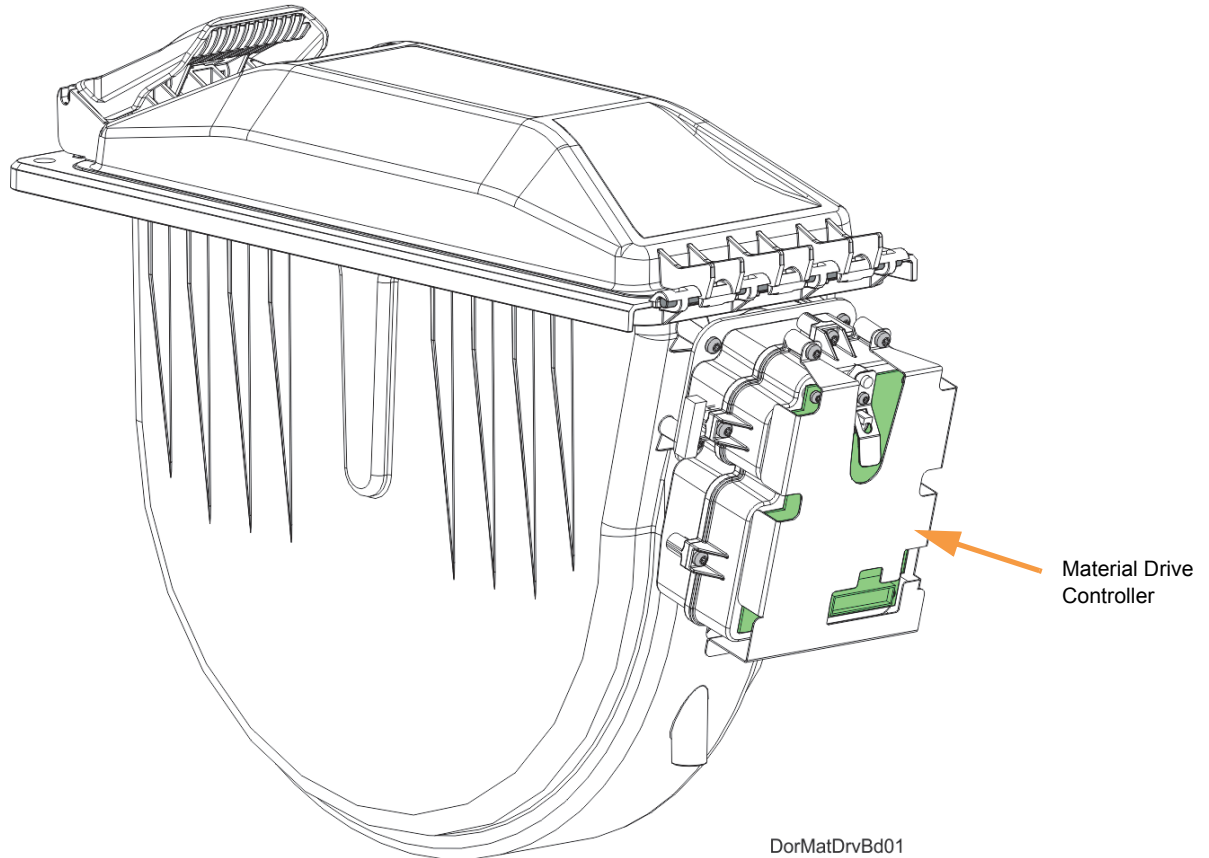

MATERIAL SPOOL MEMORY CHIP

Each material spool has an axle with a memory chip; this memory chip recognizes the spool's material type and tracks the spool's volume. The F123 Series utilizes a different memory chip than other Stratasys materials and as a result, only F123 Series compatible spools can be used to build parts on the printer.

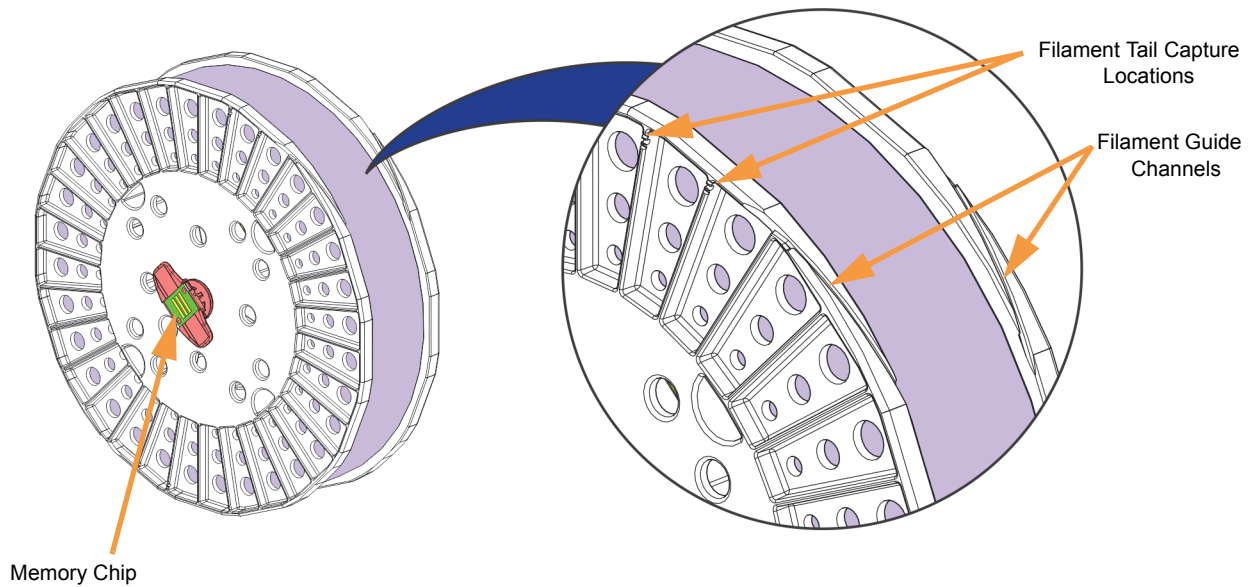

When a spool is installed, its memory chip is read and the spool's information is reported to the printer. The spool's material type and volume are displayed within the Materials page of the User Interface. If a non-compatible spool is installed an error will be displayed on the User Interface.

Each build file contains an estimate of the amount of model and support material required to complete the build. When initiating a build, this estimate is compared to the amount of material available on each spool. If there is not enough material available to complete the build, you will be warned and given the option to change spools or install additional spools before starting the build.

STORAGE DRAWER

Directly below the material bay drawer is a storage drawer which can be used to store spare parts or tools, as needed.

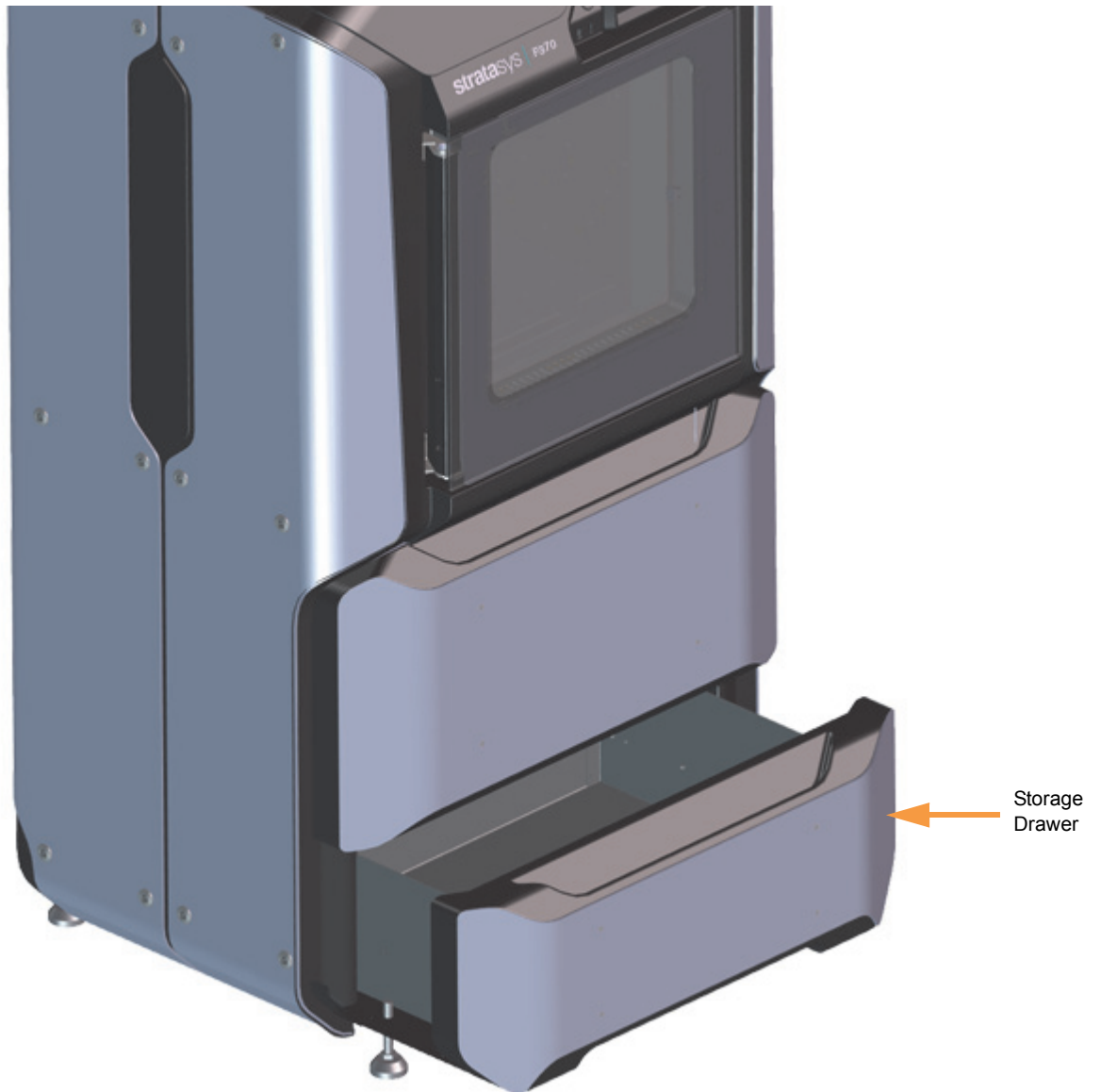

GANTRY COMPONENTS

To access the gantry or the heads, you must first open the top cover. The top cover utilizes a mechanical locking mechanism. The top cover remains locked while the printer is building and automatically unlocks when the oven door is opened. The printer cannot resume building if the top cover and/or oven door are open.

The gantry moves the head in the X and Y directions when building a part. The gantry assembly is located under the top cover. The entire gantry is outside of the oven; only the bottom of the head protrudes into the oven. The gantry and its drive motors are thermally shielded from the oven via flexible heat shields. To move the head, the gantry utilizes one X and two Y servo motors attached to timing belts.

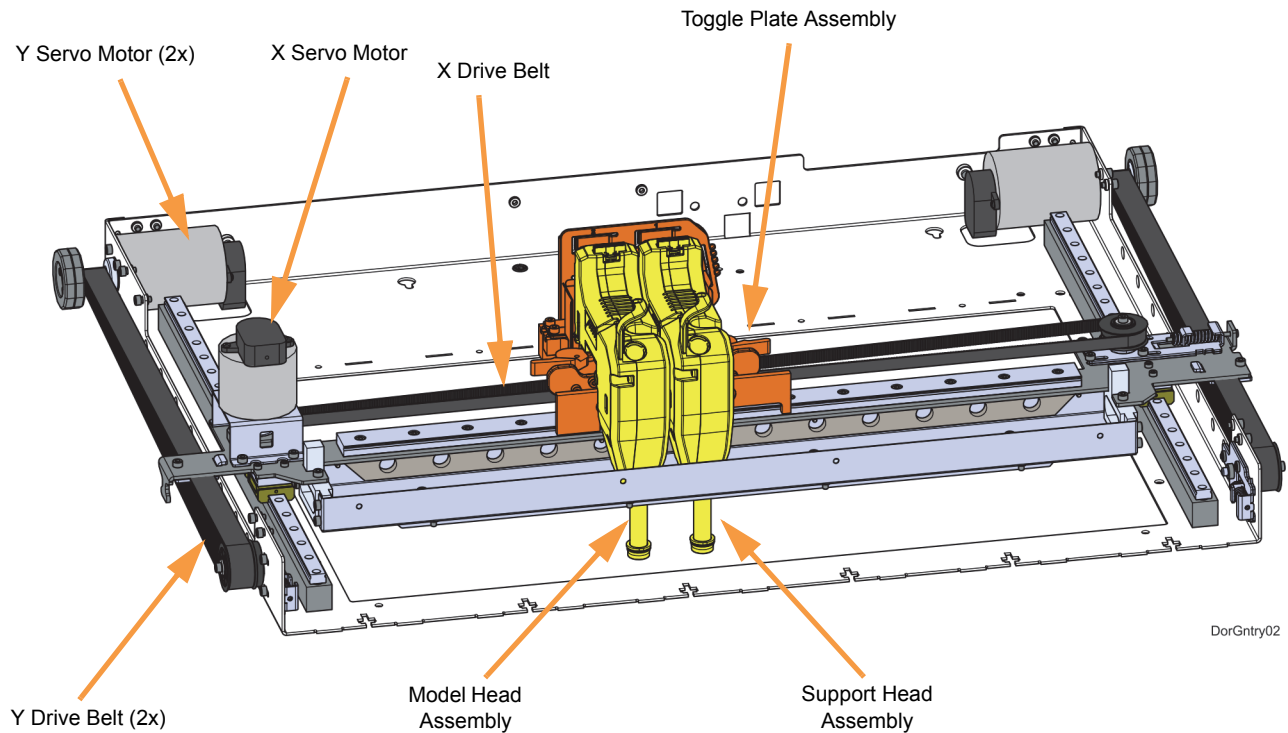

PRINT HEADS

The F123 printer utilizes two print head assemblies, one for model and one for support. Once a head has been used for model or support, it can only be used for that designated material (model or support) thereafter. The heads are designed for use with a range of modeling materials. The heads extrude model material and support material with two identical liquefiers. A single blower fan, mounted above the tip liquefier entrances, cools the incoming material at the liquefier entrances.

Head life is directly related to the amount of build time for the head. Heads are a replaceable consumable item and should be changed once the head's odometer reaches 1500 build hours. You will receive a warning when the head's odometer reaches 1350 build hours, reminding you to order a replacement head as the head is nearing its odometer limit. You can continue using a head which has exceeded its odometer limit, but it is highly recommended that you change the head as part quality will be unpredictable. The corresponding Head Status Icon will be displayed in its warning state on the User Interface. The entire model or support head assembly is replaced as a single unit. The Head Release Lever locks and unlocks the associated head into or out of its seated position.

When building with PLA material a specialized PLA head is used. The PLA head is dark gray while standard heads are black. The PLA head must be installed into the model head location within the gantry. A cooling module is used in conjunction with the PLA model head and must be be installed into the support head location within the gantry. When building with PLA material, the PLA model head extrudes both model and support materials.

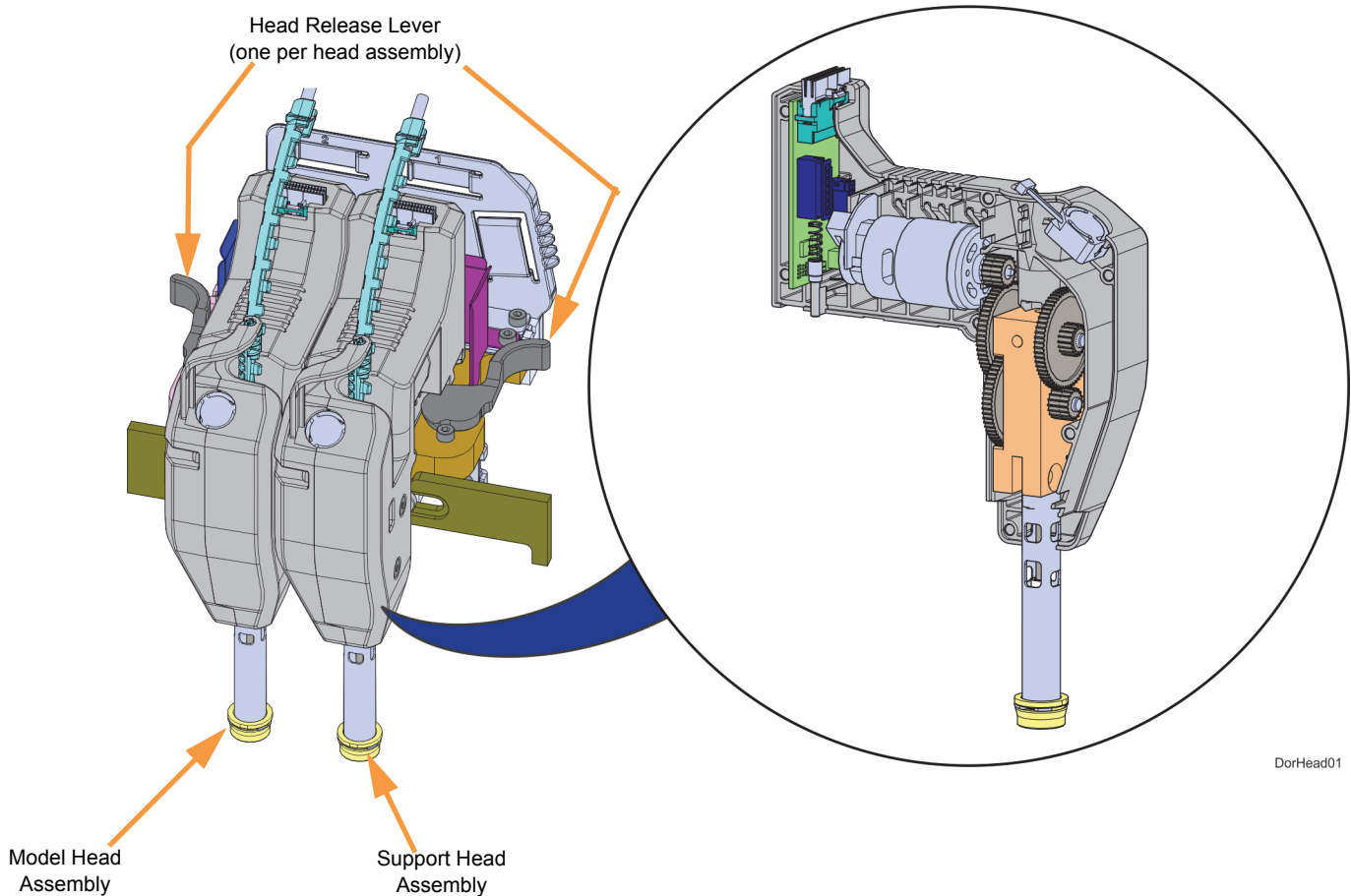

MODEL TAGS

Use the following tags to identify your printer:

- Serial Number Tag - Refer to this number when requesting service. You can also locate the printer's serial number via the Maintenance page of the User Interface.
- Model Tag - The printer's model number, part number and power requirements are given on this tag. This tag also lists all patent numbers associated with the printer, some FCC compliance information, voltage warnings, and the Stratasys web address.

Both tags are located on the back side of the printer near the bottom, and are typically placed near the printer's power connection. Use the information on these tags when identifying your printer with Customer Support.

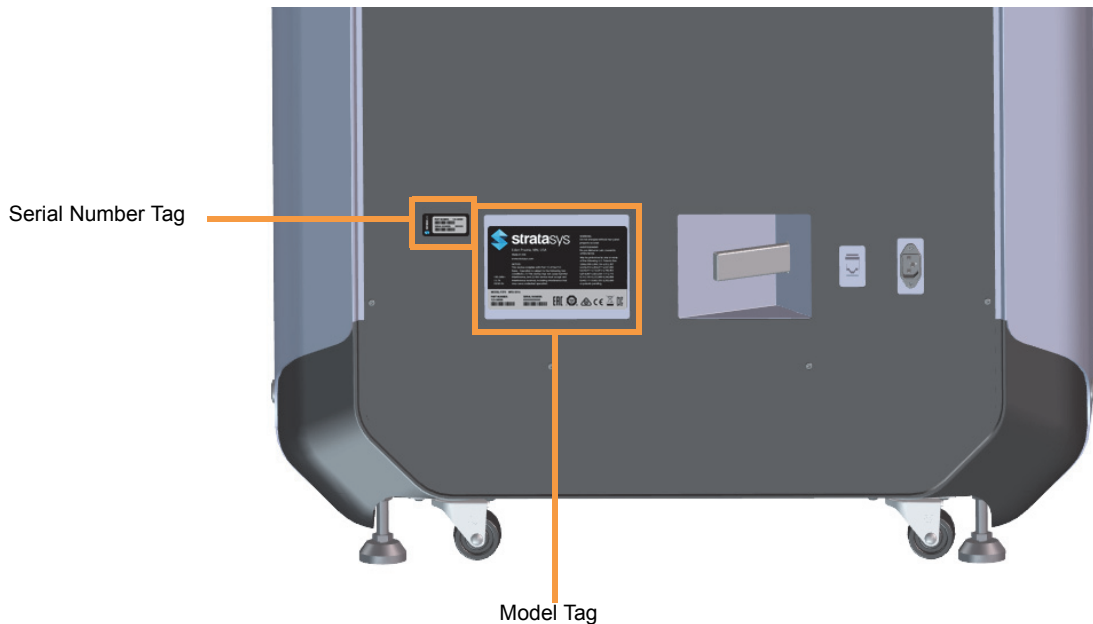

REAR CONNECTIONS

Processed job files can be transferred from GrabCAD Print to the F123 Series printer through your facility's Ethernet network. An RJ45 network connector is located on the right, rear corner of the printer (as viewed from the rear).



Note: A 15 foot (4.6m) network patch cable is supplied with the printer and located in the welcome kit. Facilities having network connection points further from the printer than can be reached by the supplied cable are responsible for the procurement of an appropriate cable.

To connect the power cable:

1. Connect the male end of the supplied power cord (US or Euro) directly into a grounded electrical outlet.
2. Connect the female end of the power cord directly into the socket located on the back of the printer.



Warning: The power cord serves as the disconnect device. The socket outlet must be easily accessible.

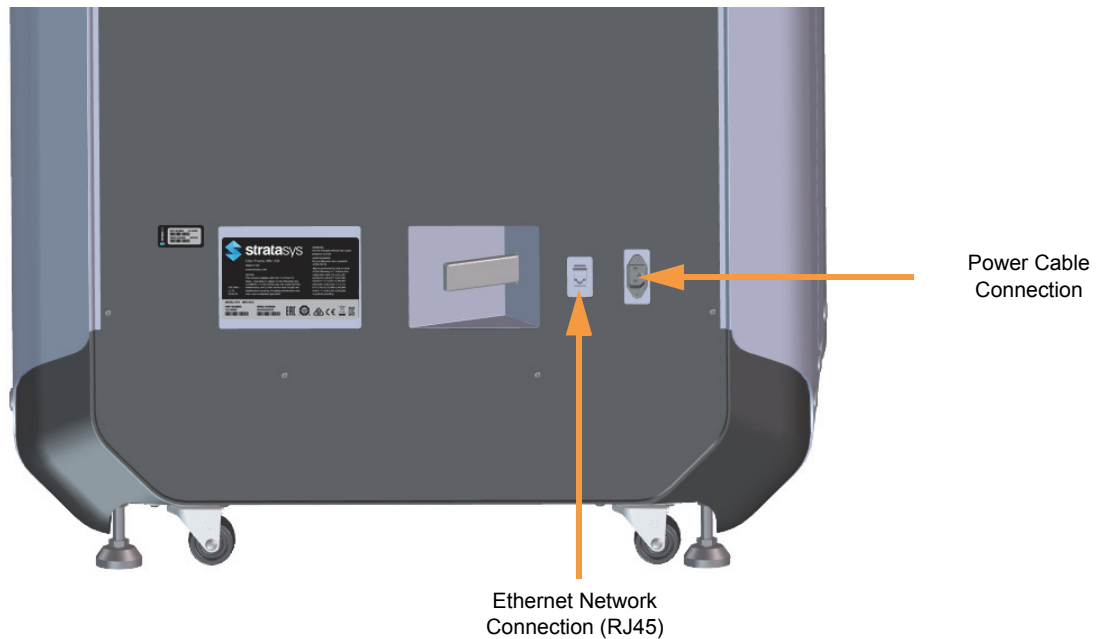

AVAILABLE MATERIALS

The F123 Series can use a variety of model materials, in a range of colors. QSR Soluble Release support material is used in conjunction with all model materials, except for PLA. When building with PLA material, PLA is used for both model and support materials.

Printer Model	Available Materials
F170	ABS, ASA, PLA
F270	ABS, ASA, PLA
F370	ABS, ASA, PLA, PC-ABS

MINIMUM CLEARANCES

Side Clearance	Minimum 4 inches (10.16 cm) on each side
Rear Clearance	Minimum 6 inches (15.24 cm)
Front Clearance	Minimum 20 inches (50.80 cm)
Overhead Clearance	Minimum 20 inches (50.80 cm)

OPERATING ENVIRONMENT

SAFE ENVIRONMENT

- Connect equipment to a grounded facility power source. Do not defeat or bypass the ground lead.
- Know the location of equipment branch circuit interrupters or circuit breakers and how to turn them on and off in case of emergency.
- Know the location of fire extinguishers and how to use them. Use only ABC type extinguishers on electrical fires.
- Know local procedures for first aid and emergency assistance at the customer facility.
- Use adequate lighting at the equipment.
- Maintain the recommended range of temperature and humidity in equipment area.
- Do not use this product in an environment containing volatile or flammable compounds.

ENVIRONMENTAL REQUIREMENTS

- The F123 Series printer is for indoor use only.
- Air quality conditions with excessive solid particulates (conductive or non-conductive) may result in system damage.
- Air quality conditions in which airborne oils are allowed to accumulate on or within the printer can damage the plastic components.
- System operating temperature shall be in the range of 59°F to 86°F (15°C to 30°C), with relative humidity range of 30% to 70% non-condensing.
- System storage temperature shall be in the range of 32°F to 95°F (0°C to 35°C), with relative humidity range of 20% to 90% non-condensing.
- Altitude shall not exceed 6561.68 feet (2000 m).
- Material storage shall be in the range of 55°F to 86°F (13°C to 30°C), with relative humidity less than 70%.
- Noise emission (acoustic):
 - <32dBA when idle
 - <46dBA when building

TOOLS/WELCOME KIT CONTENTS

The printer's Welcome Kit contains the Welcome Insert document and common tools you will need to maintain the printer. Use the following figures and tables to identify the contents of the Welcome Kit.

Figure 1: Welcome Kit Contents - Document and Cables

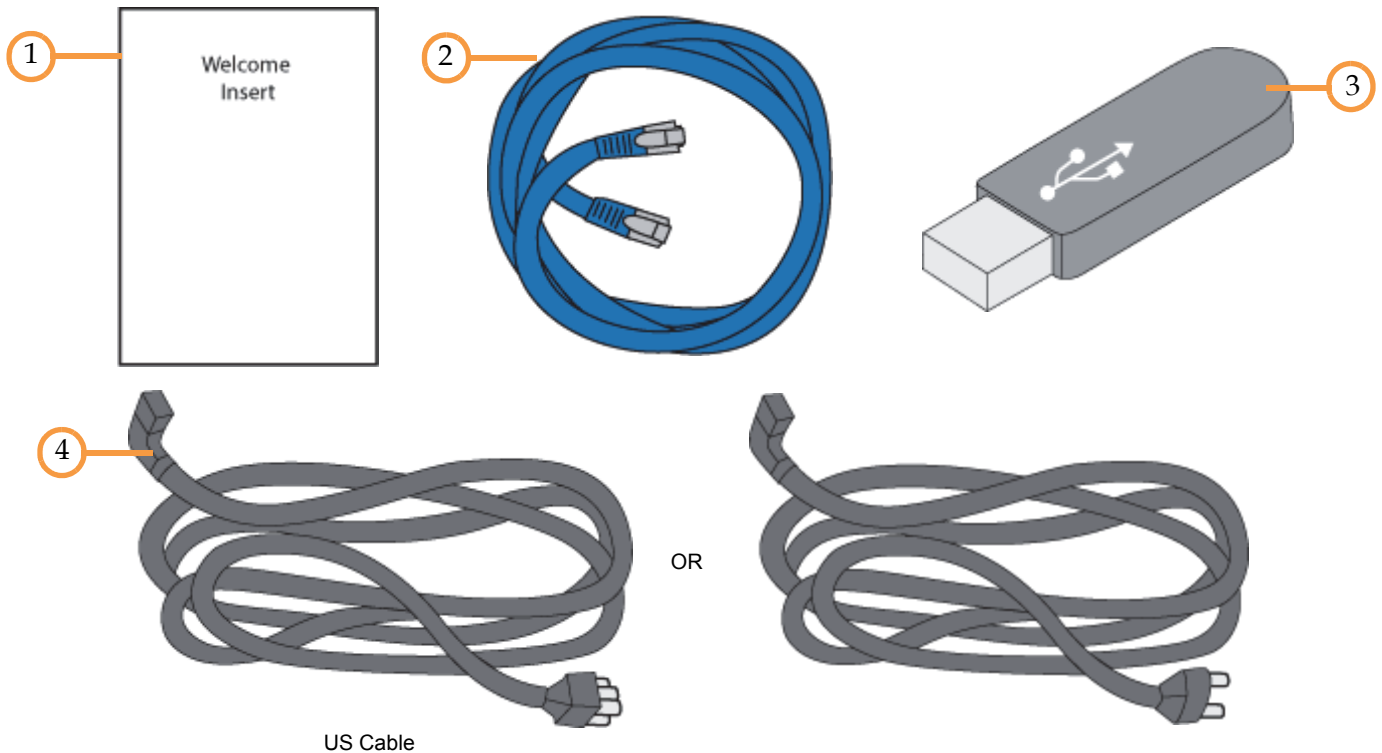

Key for Figure 1

1	Welcome Insert Document	Contains instructions for downloading the F123 Series User Guide (this document).
2	RJ45 Cable	This cable is used to establish a network connection between the F123 Series printer and your Ethernet network.
3	USB Flash Drive	The printer features 3 USB ports. As an alternate method to sending job files to the printer via GrabCAD Print, this flash drive can be used to store processed job files which you build frequently.
4	AC Cable (US or Euro)	This cable provides the power connection to the printer. When connecting the cable, select the cable appropriate for your location (US cable or Euro cable).

Figure 2: Welcome Kit Contents - Tools

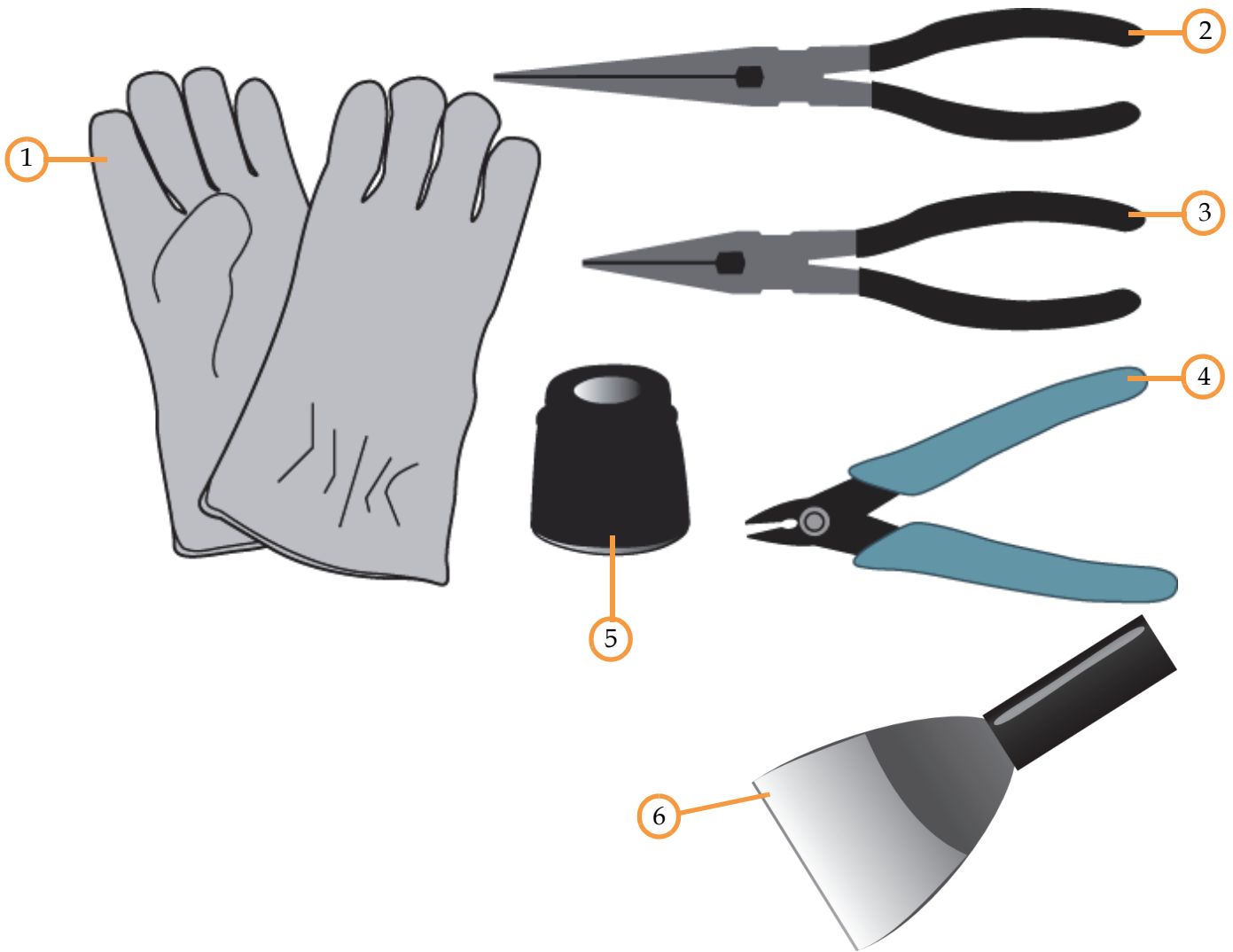

Key for Figure 2

1	Leather Safety Gloves	Printer components may be extremely hot. To prevent burns or other injuries, these gloves should be worn any time you see the gloves safety sign throughout this document.
2	Needle Nose Pliers (extra slim)	Occasionally, you may need to use pliers to aid in the clearing of debris which have accumulated on the head and/or tips.
3	Needle Nose Pliers (7 1/8)	Occasionally, you may need to use pliers to aid in the clearing of debris which have accumulated on the head and/or tips. Please note, this item is not included for F170 printers.
4	5" Cutters	These are used to cut a material spool's filament when unloading and removing materials from the printer.
5	Loupe Magnifier	This tool is included to aid you with performing a Manual Tip Calibration which requires you to view small toolpath relationships.
6	Scraper	This tool is used to scrape parts or material off the substrate.

Figure 3: Welcome Kit Contents - Cleaning Supplies and Storage Materials



Key for Figure 3

1	Touchscreen Cleaning Kit	From repeated use, the touchscreen may become dirty and occasionally need to be cleaned. Only use suitable LCD cleaning agents when cleaning the touchscreen.
2	Microfiber Cloth	Various components of the printer may become dirty and occasionally need to be cleaned. Only use a suitable microfiber cloth to clean these components.
3	Resealable Bag (x6)	When unloaded, non-empty model and support material spools should be stored within these bags to prevent moisture from contacting the spool's filament.
4	Nitrile Gloves (x10)	Gloves used for Y-rail lubrication preventive maintenance
5	AFF Grease	Grease used for Y-rail lubrication preventive maintenance (70 gram tube)

Figure 4: Additional Components - Startup Materials

The following items are not located within the Welcome Kit. Instead, they can be found within the oven chamber and the storage drawer. The items found within the oven chamber must be removed before powering the printer ON.

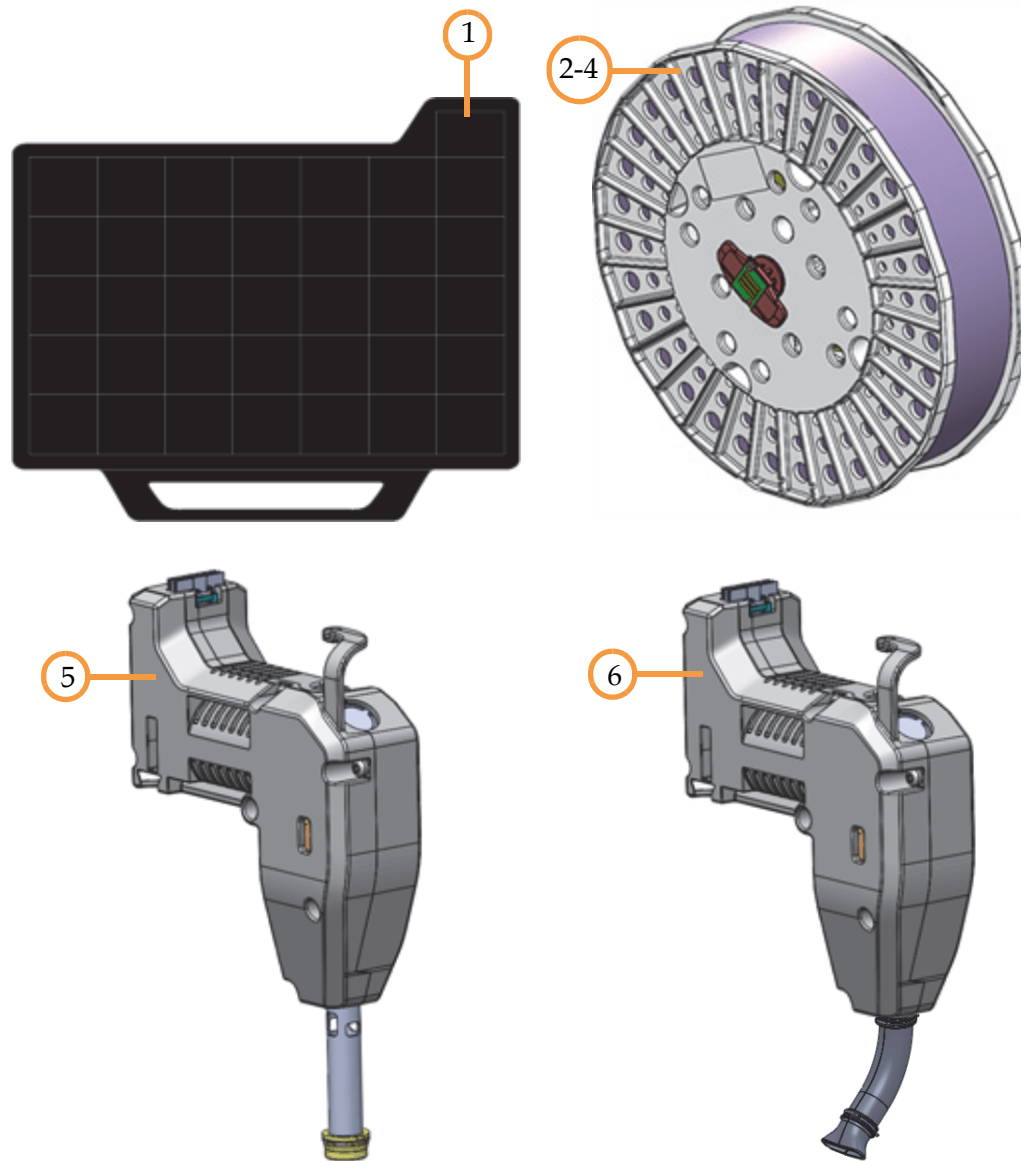

Key for Figure 4

1	Substrate (x16)	A substrate is the surface upon which a part is built. The same substrate is used for all model materials, including PLA.
2	ABS Model Material Spool	Material spool containing 60 in ³ (984 cc) of ABS model material.
3	QSR Support Material Spool	Material spool containing 60 in ³ (984 cc) of QSR support material.
4	PLA Material Spool	Material spool containing 60 in ³ (984 cc) of PLA material.
5	PLA Model Head	Print head for use with PLA model material only.
6	PLA Cooling Module	Cooling module to be used in conjunction with the PLA model head.

SAFETY INFORMATION

The following basic safety tips are given to ensure safe installation, operation, and maintenance of Stratasys equipment and are not to be considered as comprehensive on matters of safety. The Fortus 450mc printer is designed to be a safe and reliable rapid prototyping printer. Access to areas of the printer are potentially dangerous.

HAZARD TYPES

Stratasys recommends that all services be performed by qualified personnel. All personnel working on or around this printer should be knowledgeable of what the following hazard classifications mean throughout this guide.

- **Warnings** and **Cautions** precede the paragraph to which they pertain.



Warning: Indicates a potentially hazardous situation which, if not avoided, may result in injury or death.



Caution: Indicates a situation which, if not avoided, could result in damage to equipment.



Note: Indicates additional information relative to the current topic.

SAFETY SYMBOLS



Note: Always read and adhere to safety statements, and be aware of the following safety signs when you see them on the printer.

Stratasys makes every effort to ensure that our printers are safe and reliable at all times. However, there will be times when you must access areas of the printer where potentially high voltages, hot temperatures, and/or moving mechanical components could cause severe injury.



High Voltage: The high voltage sign indicates the presence of high voltages. Always stay away from any exposed electrical circuitry. It is recommended that all jewelry be removed.



Hot Surface: The hot surface sign indicates the presence of devices with high temperatures. Always use extra care when working around heated components. Always wear the safety gloves provided in the Welcome Kit.

Head temperatures in the printer can exceed 450°C (800°F).



Gloves: The gloves sign indicates that if you enter the area specified by the symbol you must wear safety gloves (provided in the Welcome Kit) which have been approved for high temperatures.



Crushed Hand: The crushed hand sign indicates that a hazard exists where you could get your hand crushed between two objects. One or more objects move in the area that you are working.

OVEN SAFETY LABEL LOCATIONS

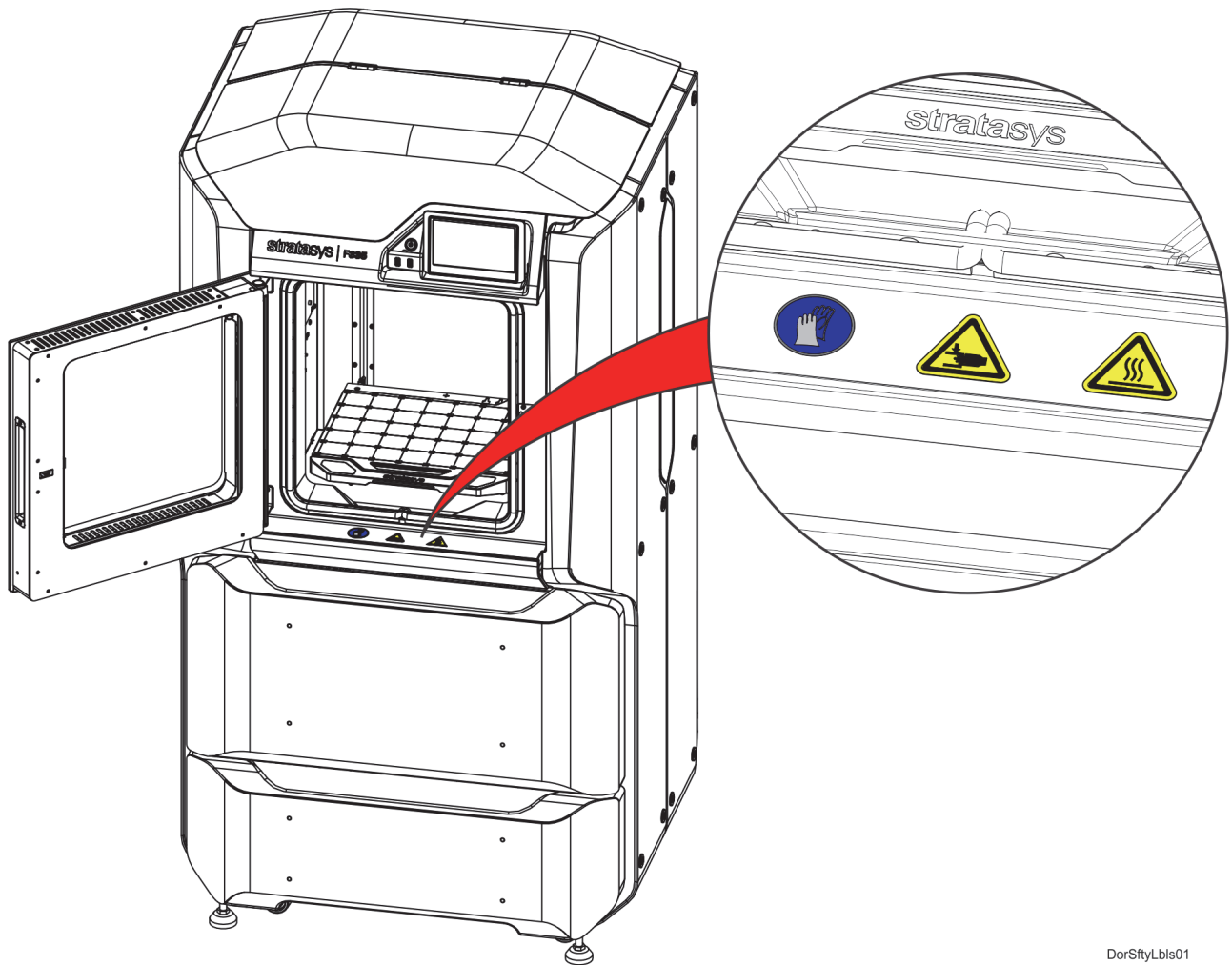

DorSftyLbIs01

REAR SAFETY LABEL LOCATIONS

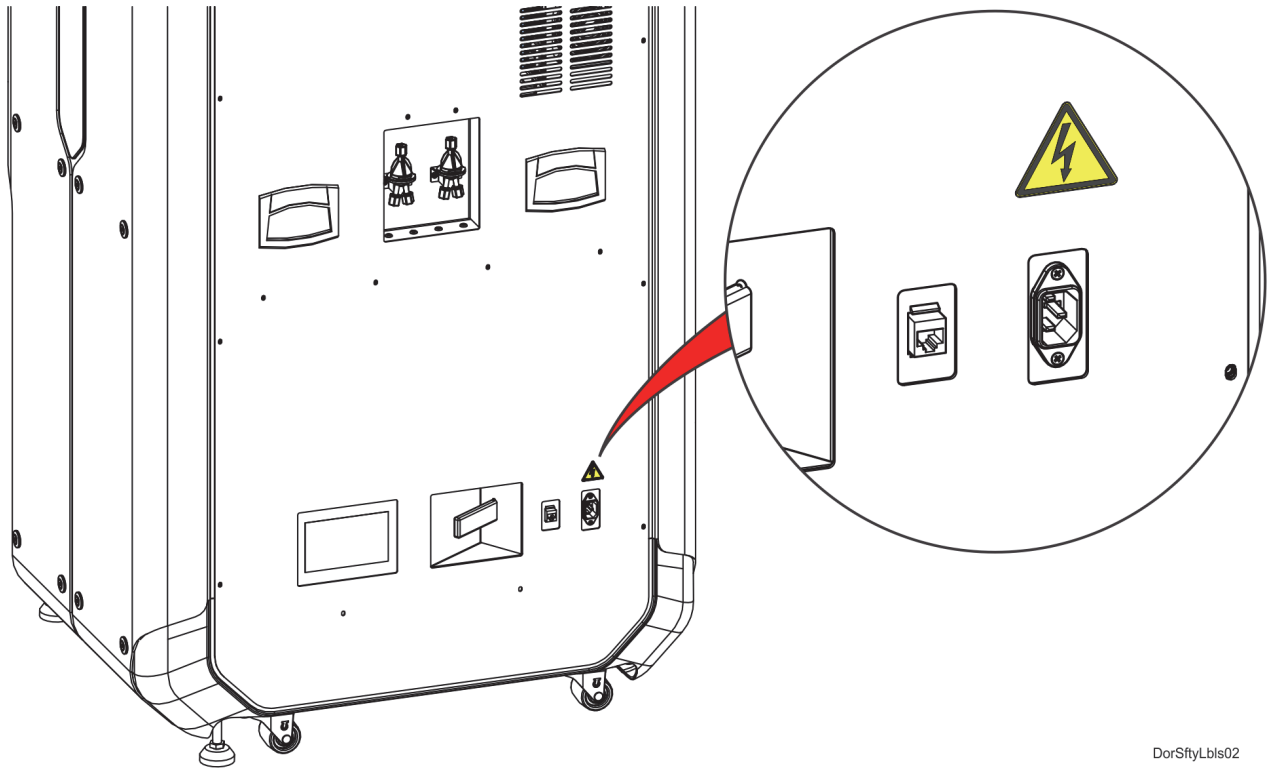

DorSftyLbIs02

ELECTRICAL PANEL SAFETY LABEL LOCATIONS

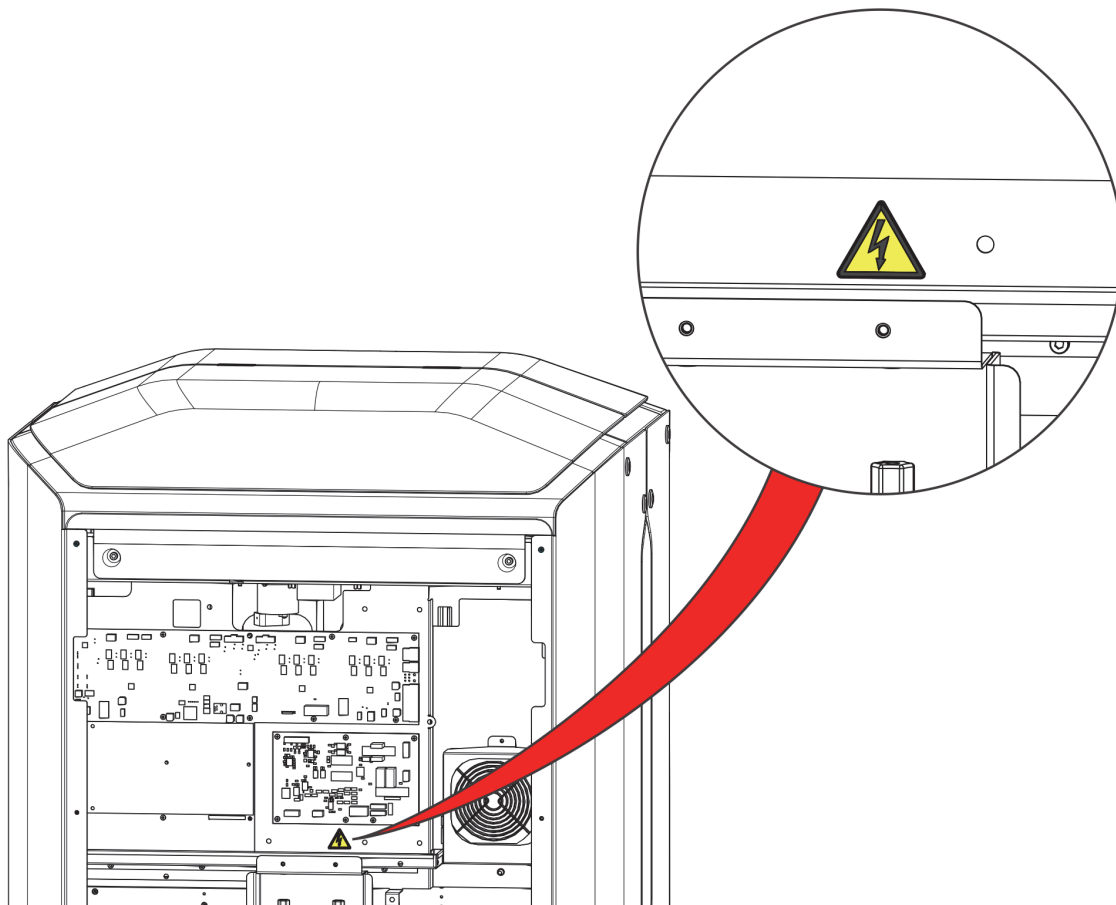

SAFETY PRECAUTIONS

The following components and areas of the printer are potential safety hazards. Take adequate precautions when using and maintaining the printer.

OVEN



Warning: Always wear safety gloves and long sleeves when working inside the oven. Components are hot.



Note: Opening the oven door shuts the oven heaters off.

GANTRY



Warning: Never wear a tie, loose clothing or dangling jewelry when working around moving components of the printer.

Beneath the top cover of the printer is the gantry. This area houses the mechanical drive components of the X and Y axes. Use extreme caution whenever accessing this area of the printer.



Note: The printer's servo motors are disabled when the oven door and/or top cover are open. The XY pinch hazard between the timing belts and pulleys is minimized by locking the oven door and top cover while building and disabling the motors when the oven door and top cover are open. The oven door and top cover automatically lock when the printer is building and cannot be opened while the printer is building. You cannot start a build if the oven door or top cover are open.

Z STAGE



Warning: Never wear a tie, loose clothing or dangling jewelry when working around moving components of the printer.

The drive belt, pulleys and Z stage servo motor can cause severe injury. The Z stage crushing hazard is minimized by locking the oven door during Z stage moves and disabling the Z motor when the oven door is open.

DOOR LOCKS

Sensors are used to communicate the status of the oven door and the top cover to the printer. For safety reasons, the oven door and top cover must be closed before the X, Y, and Z motors will operate.

STABILITY PADS



Caution: The stability pads are used to stabilize the printer after it has been moved to its desired operating location. The stability pads must be set prior to printer operation.

To stabilize the printer:

1. Roll the printer to its desired operating location and verify that minimum space requirements have been met.
2. Thread the stability pad jackscrew downward until the stability pad makes contact with the floor.
3. Turn the jackscrew an additional 1-2 turns downward and set the locknut firmly against the lower frame member.



Note: Ideally, each caster wheel will remain in slight contact with the floor and using minimal force, be able to be rotated.

4. Repeat [step 2](#) and [step 3](#) to set all remaining stability pads.

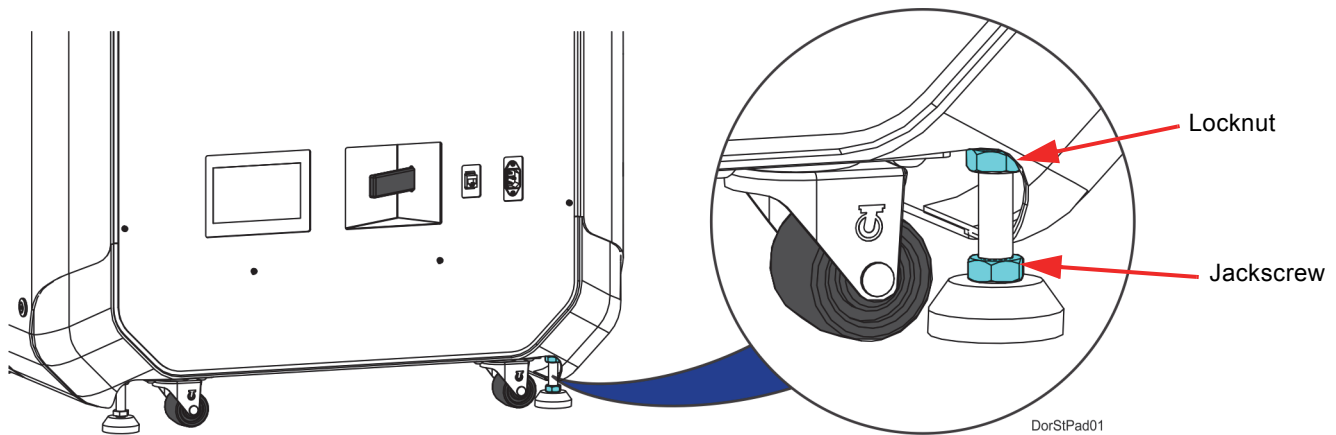

GENERAL SAFETY PRACTICES

Abide by these general safety practices when working with this printer.



High Voltage: High voltage is present in the printer.



Warning: Only use an OSHA or CE approved step stool when accessing the area under the top cover of the printer.



Warning: Always wear safety gloves and long sleeves when working in the oven, with the head, or liquefier tips. These components are very hot.

BASIC USER OPERATIONS

POWERING ON THE PRINTER

To power the printer ON:

1. Connect the male end of the supplied power cord directly into a grounded electrical outlet.
2. Connect the female end of the power cord directly into the socket located on the back of the printer.
3. Press the **Power** button located on the front of the printer.

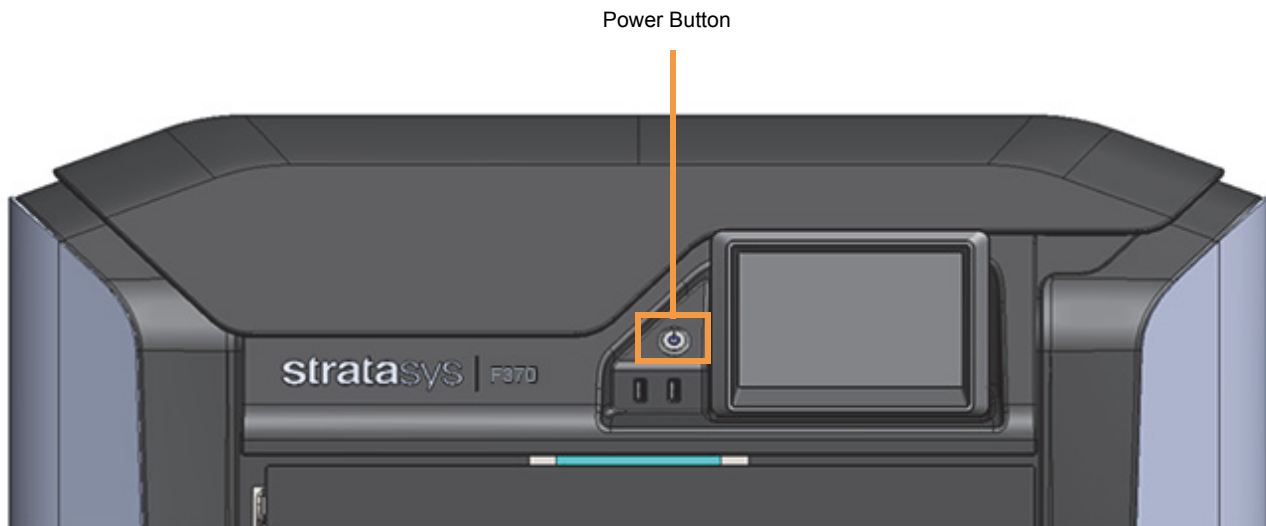

4. The printer will begin to boot. The touchscreen will turn on and begin initializing.
5. The first time the printer is powered ON a dialog will be displayed asking you to select your desired language. Select the radio button corresponding to your desired language by touching its row on the screen, then confirm your selection.



6. After the initialization and start up process is complete, the touchscreen will refresh to display the Build page and the printer will automatically perform an XY Gantry Calibration.

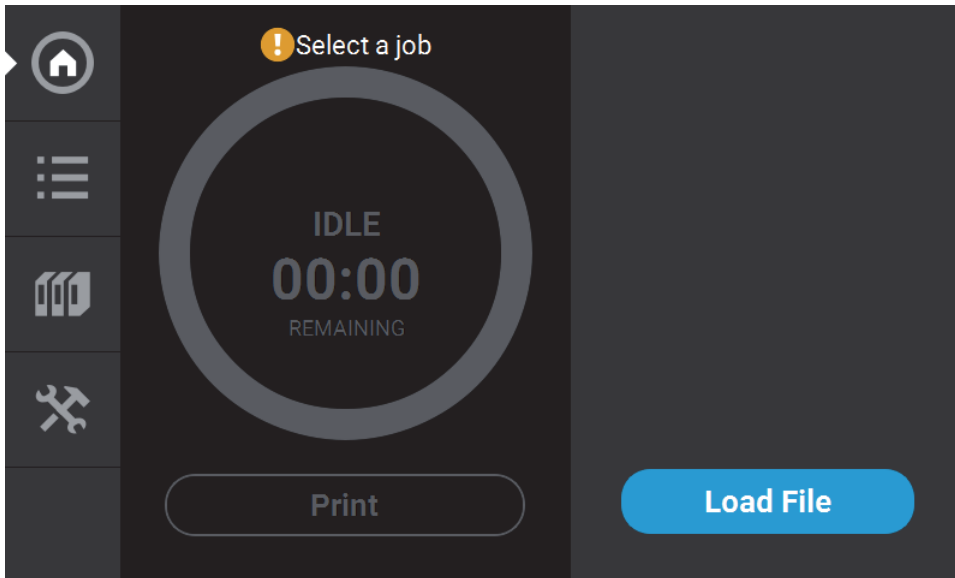

POWERING OFF THE PRINTER

To power the printer OFF:

1. Ensure that the printer is stopped (idle) and is not building.
2. Press the **Power** button located on the front of the printer.
3. A dialog will be displayed asking you to confirm the power OFF; press **Yes** to power OFF.

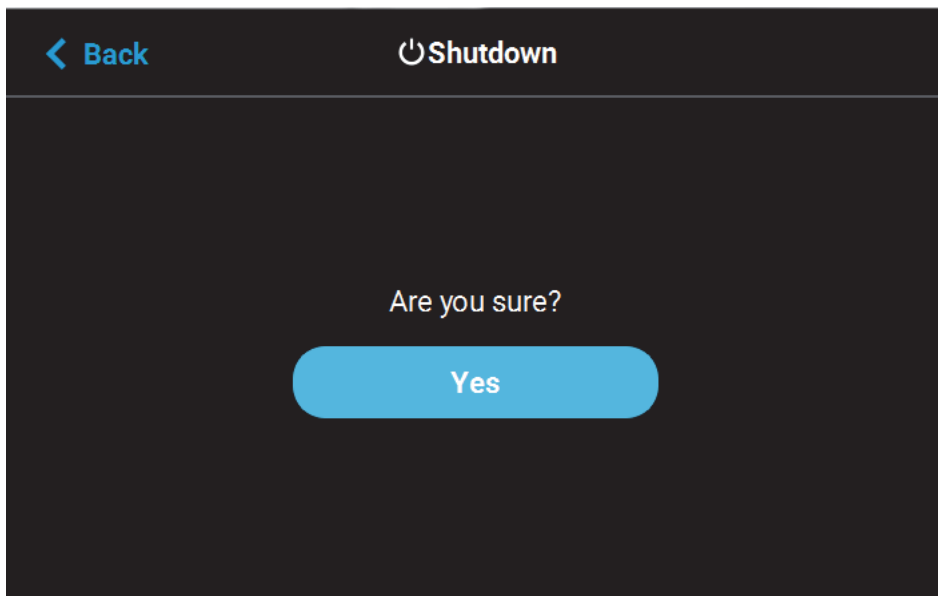

4. After a couple of minutes the printer will shutdown.

Please note that this procedure only powers down the electronics. To completely disengage power to the printer, you must unplug the power cord located at the rear of the printer.



Note: For extended non-use periods greater than 72 hours, unload the material, store the material in an air tight bag and power OFF the system.

CONFIGURING THE NETWORK

This section is provided in case you need to change your network settings. Within the Network page you can set your printer's address type to Static, Dynamic (DHCP), or Wi-Fi; Dynamic is selected by default.

- Static address - you must enter an IP address, subnet mask, and gateway address for the printer (provided by the system administrator). Once entered, the address will not change.
- Dynamic address (DHCP) - a network server or PC will generate an IP address for the printer. A different IP address may be generated from time to time by the server or PC.
- Wi-Fi address - the printer will scan for and allow you to connect to an available Wi-Fi network (if the Wi-Fi dongle has been installed).

To configure your printer's network address settings:

1. Power ON the printer.
2. Open the Tools page by pressing the **Tools** button within the Navigation Menu.
3. Open the Network page by pressing the **Network** button within the Tools page.
4. The **Connection Type** row allows you to select between a wired or wireless network. The option selected will determine the configurable settings displayed within the Network page.
 - Selecting the **Wired** option will allow you to select between a Dynamic or Static network mode.
 - Selecting the **Wireless** option will configure the printer to use a Wi-Fi network. You will need to scan for a wireless network and enter the security settings for the selected network (if required) to complete the configuration. Please note that the availability of the Wireless option depends upon the configuration purchased with your printer.
5. After selecting the radio button corresponding to the connection type you'd like to use (wired or wireless) press the **Back** button in the upper-left corner of the page to return to the Network page.
6. For wired networks:
 - A. The **Network Mode** row will be displayed. Press anywhere within this row.
 - B. Select either the **Static** or **Dynamic** radio button to enable that network address type. Depending on the option selected, you may need to configure additional information within the Network page.

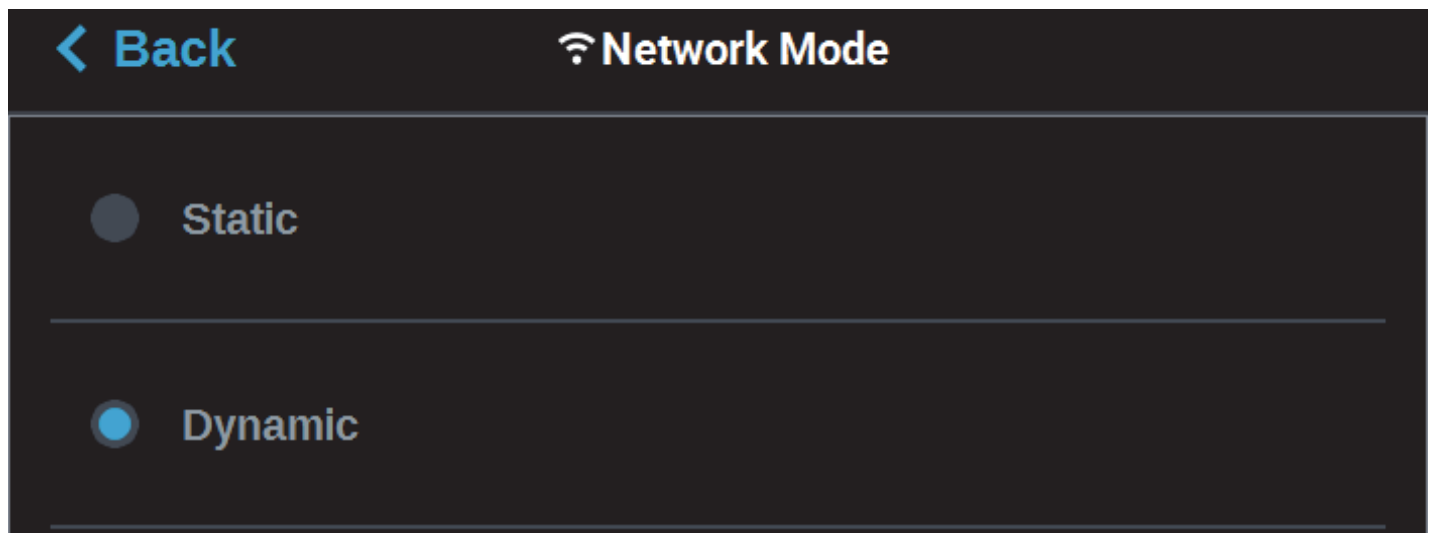

- If the **Static** option is enabled, you must manually configure the IP Address, Subnet Mask, and Gateway Address fields. To configure this information simply touch a field on the screen to select it and then use the keypad displayed to enter address information.

- Touch anywhere on the screen outside of the keypad to exit and close the keypad.

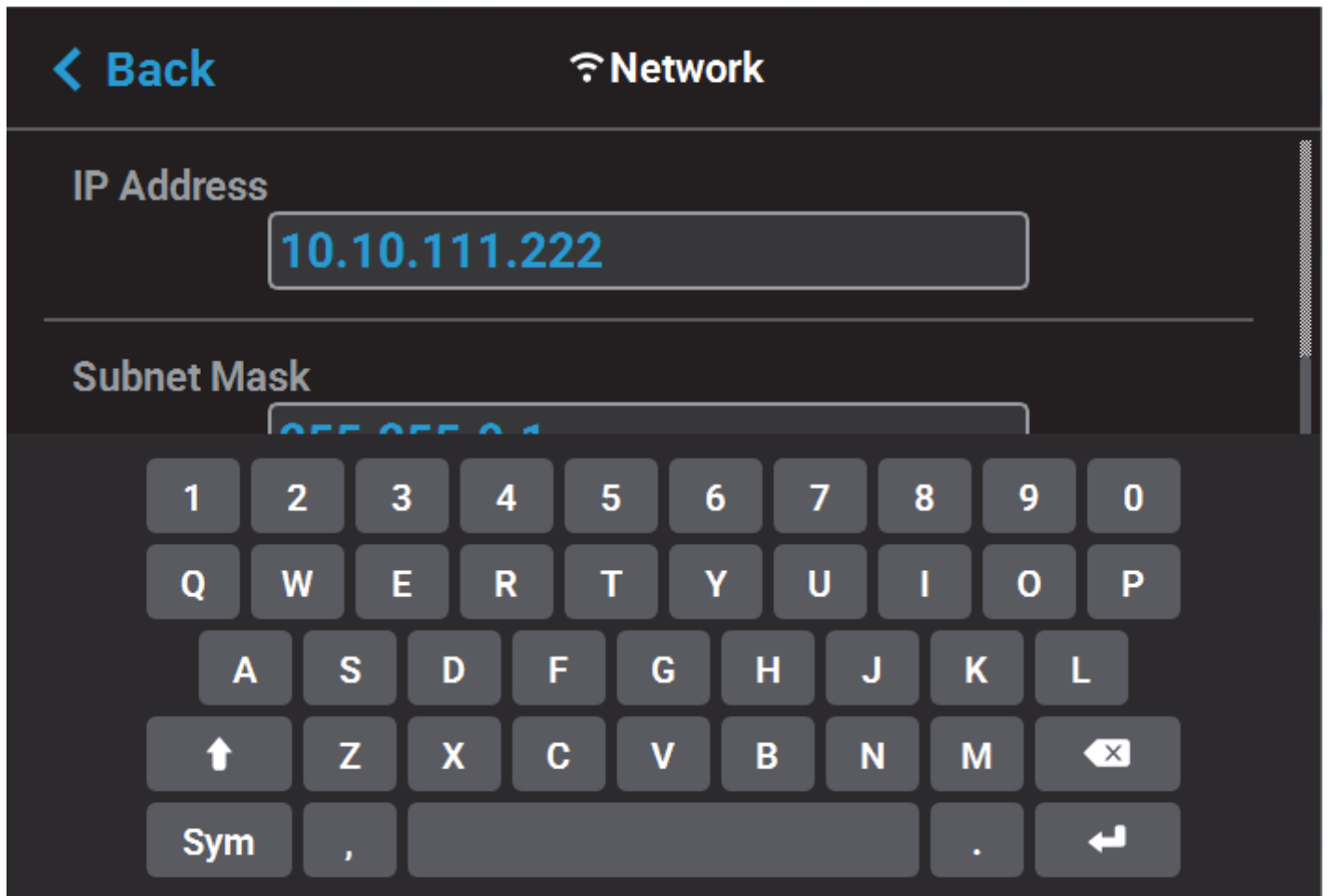

- Scroll to the bottom of the page and press the **Apply** button when finished to save the network configuration.
- Press the **Back** button in the upper-left corner of the page to return to the Network page.

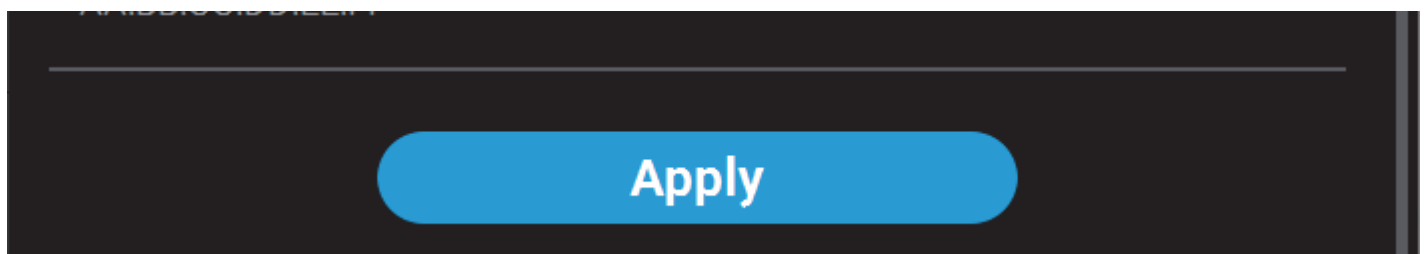

- If the **Dynamic** option is enabled, no additional configuration is necessary as a network server or PC will automatically generate an IP address for the printer. A different IP address may be generated from time to time by the server or PC; the generated IP address will be displayed within the IP Address field of the Network page, and corresponding Subnet Mask and Gateway Address information will also be displayed.
- Press the **Back** button to exit the page and return to the Tools page.

The screenshot shows a dark-themed interface for network configuration. At the top left is a blue back arrow and the text 'Back'. At the top right is a Wi-Fi icon and the text 'Network'. Below this are four rows of configuration fields, each with a label and a text input box:

- IP Address**: 10.10.111.222
- Subnet Mask**: 255.255.0.1
- Gateway Address**: 10.10.112.1
- MAC Address**: AA:BB:CC:DD:EE:FF

7. For wireless networks:
 - A. The **Available Networks** row will be displayed (Wi-Fi dongle must be installed). Press anywhere within this row.
 - B. Press the **Scan** button; the printer will scan for an available wireless (Wi-Fi) network.

The screenshot shows a dark-themed interface for available networks. At the top left is a blue back arrow and the text 'Back'. At the top center is a Wi-Fi icon and the text 'Available Networks'. At the top right is a blue button with the text 'Scan'. Below this are two rows of network entries, each with a Wi-Fi icon, the network name, and a right-pointing arrow:

- MyNetwork1**
- MyNetwork2**

- C. A list of available networks will be displayed; select the wireless network you'd like to connect to by pressing anywhere within the row.
- D. A page will be displayed containing the details of the selected Wi-Fi network. Within this page use the keyboard to enter the password and/or username required to connect to the network.

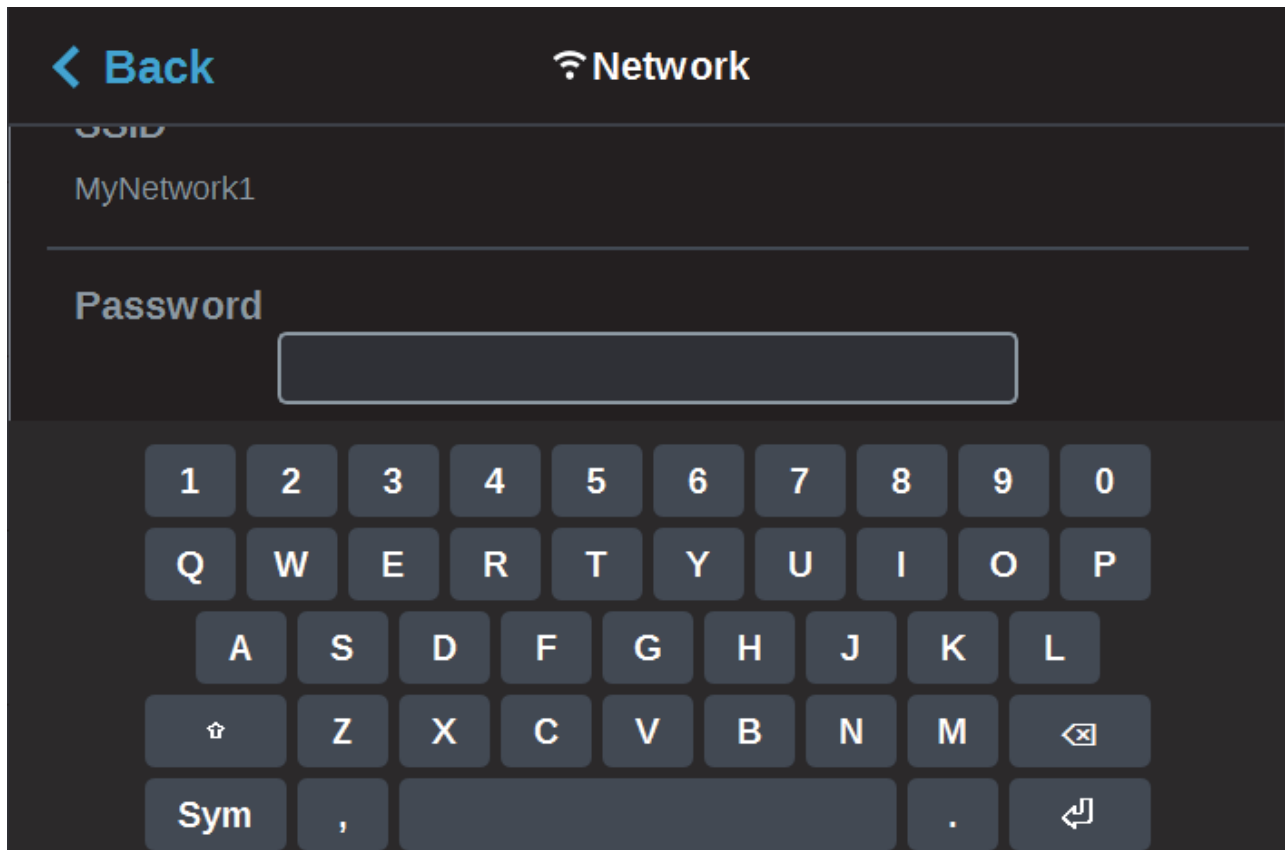

- E. When finished, touch anywhere on the screen outside of the keypad to exit and close the keypad.
- F. Scroll to the bottom of the page and press the **Connect** button to save the network configuration.

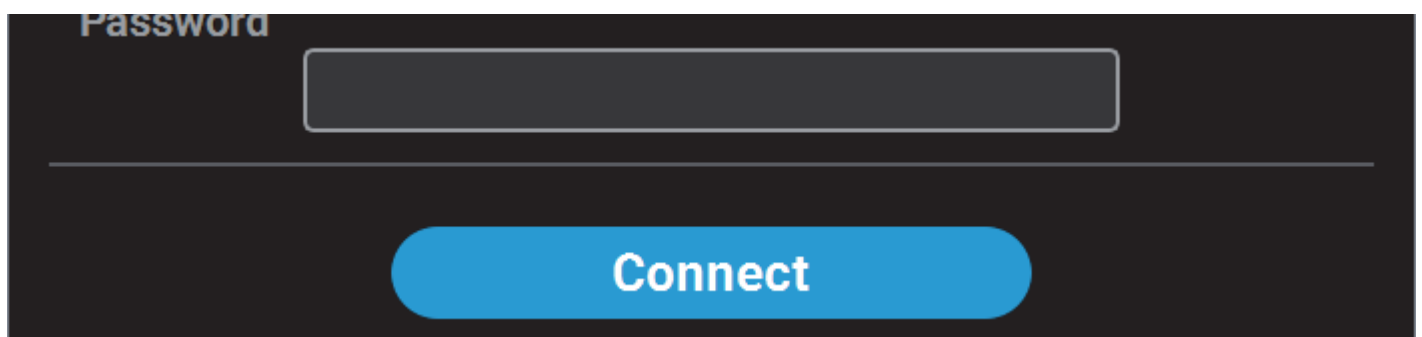

- G. Press the **Back** button to exit the page and return to the Network page. The name of the selected wireless network will be displayed within the Available Networks row.

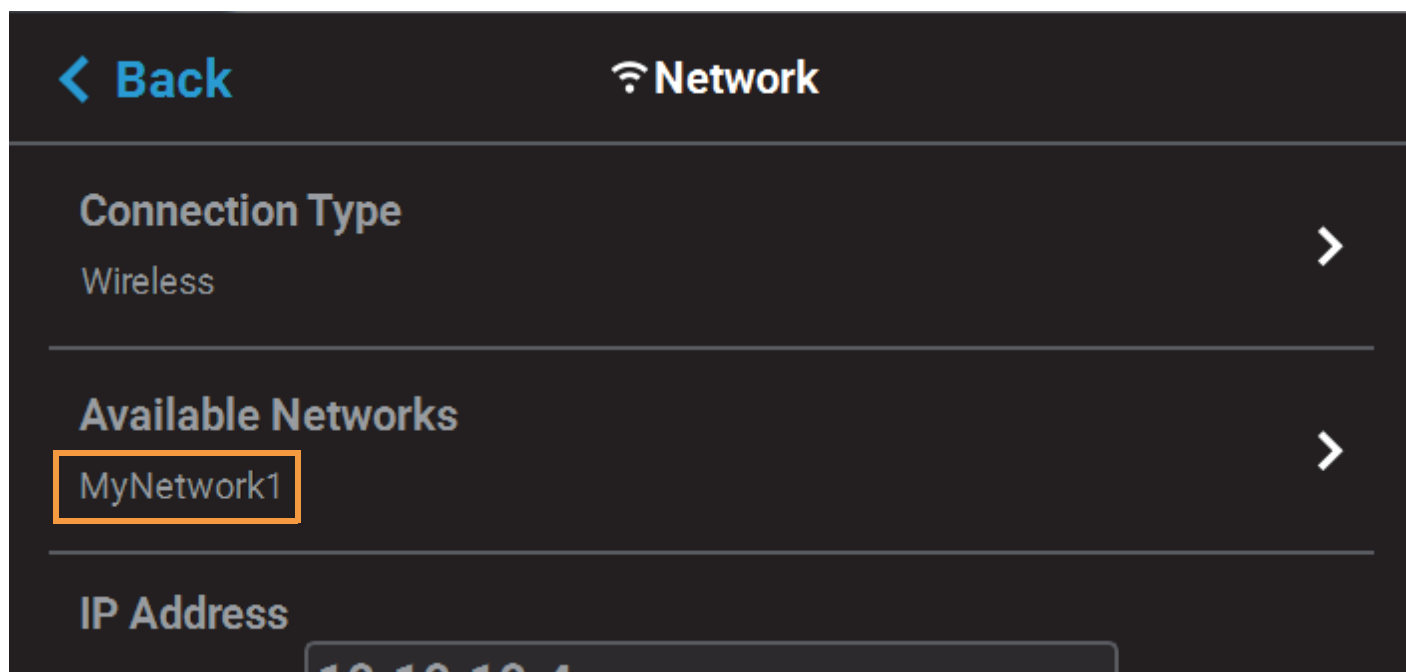

- H. Press the **Back** button to exit the page and return to the Tools page. The Network button will refresh and a blue indicator will be displayed indicating that the printer is configured for a Wi-Fi network.



USER INTERFACE

The User Interface is composed of a touchscreen located on the front right face of the printer. Each page of the UI is composed of two main areas of functionality; these items are highlighted in the following figure.

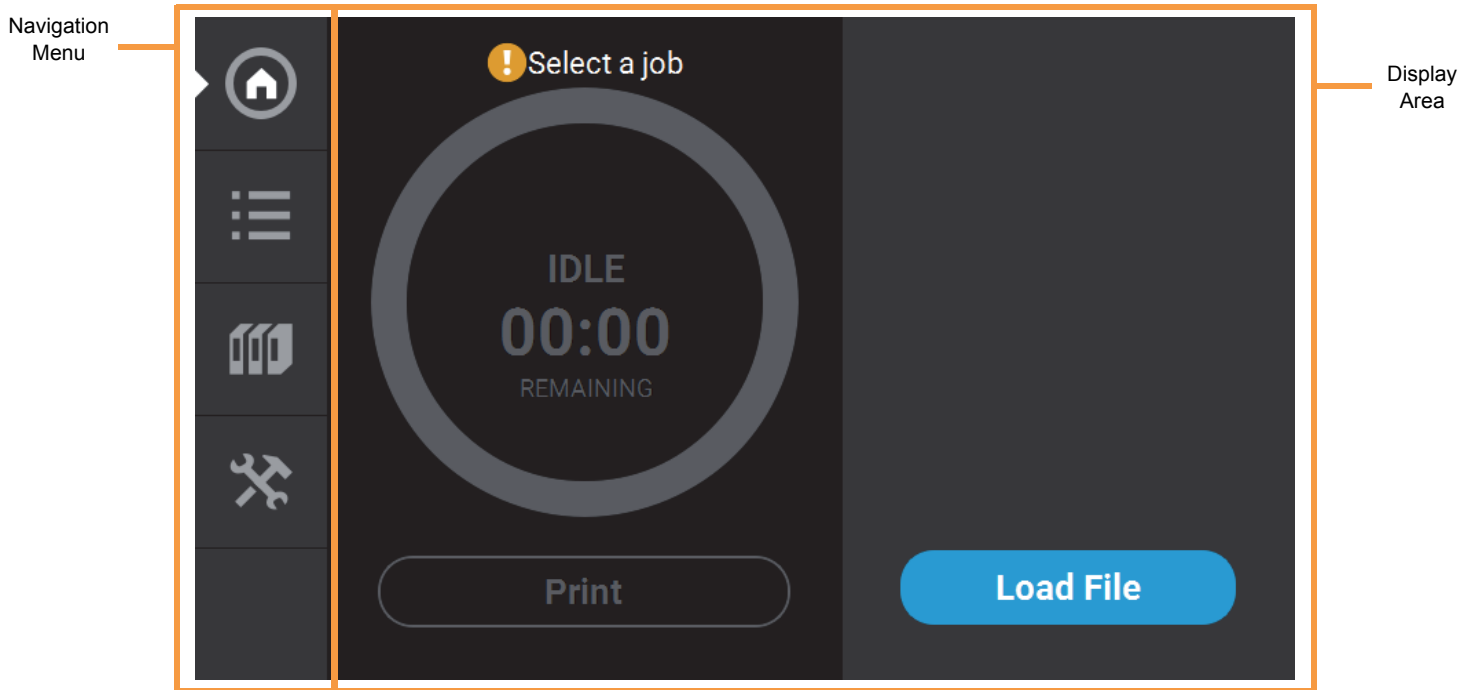

The touchscreen is designed to reduce glare; therefore, it is best to view the touchscreen when standing in front of the printer with the screen to your right. Viewing the touchscreen from any other angle may inhibit a clear view of the screen's display. The touchscreen is easy to use and allows you to:

- Access material load, unload, and calibration functions.
- Monitor printer status.
- Monitor material/head statuses (types loaded/installed, spool volumes, head odometers, etc.) and change materials and/or heads when necessary.
- Monitor build progress (name of job being built, materials usage information, estimated completion time, etc.).
- Access network configuration information and change printer defaults.
- Access the Job Queue and Sample Queue (internal storage).

NAVIGATION MENU

The Navigation Menu provides one-touch access to the Build, Queue, Materials, and Tools functions of the printer. The User Interface is broken up into several pages of related functionality. Selecting a button from the Navigation Menu will open the button's corresponding page, allowing you to perform tasks within that page. If a page contains sub-pages, additional buttons corresponding to these items will be displayed within the page's Display Area.

The buttons in the Navigation Menu are mutually exclusive, meaning only one button may be selected at a time. In some cases, a notification badge will be displayed within the button indicating a warning related to the functionality of the corresponding page. Buttons can appear as follows:



Note: The bottom-most button in the Navigation Menu is non-functional.

Navigation Menu - Button States

Button Name	Selected State	Unselected State	Warning State		Error State	
			Unselected	Selected	Unselected	Selected
Build Button						
Queue Button			N/A	N/A	N/A	N/A
Materials Button					N/A	N/A
Tools Button			N/A	N/A	N/A	N/A

After selecting a button from the Navigation Menu, a white indicator graphic will be displayed along the left-center edge of the button. This graphic indicates which Navigation Menu item is currently selected, making it easy for you to recognize which page of the UI you're utilizing.

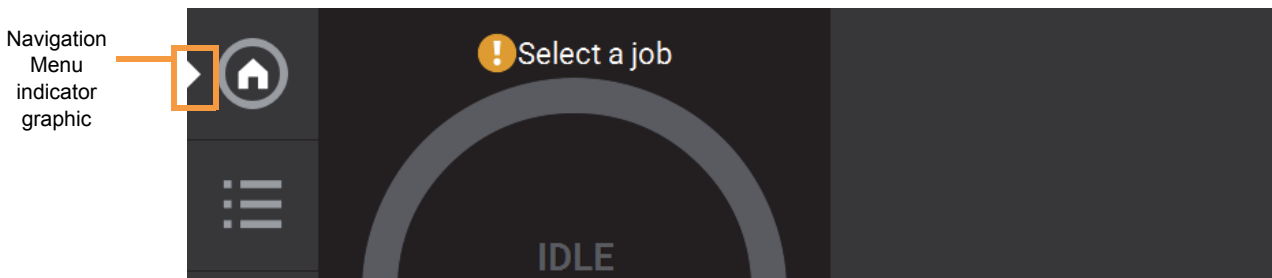

DISPLAY AREA

The Display Area contains the body portion of each page of the User Interface; this is where you can select from available functions and view current status. After selecting a button from the Navigation Menu, the Display Area will refresh and the main page corresponding to the selected button will be displayed. The information and buttons/icons shown within the Display Area will vary depending on which main page of the UI was selected.

BUILD PAGE

The Build page is composed of the three main areas of functionality that are necessary for building parts on the printer; these items are highlighted in the following figure. Within the Build page you can start, pause, and abort a job, view a build time estimate for the selected job, see status and estimated action points for a job in progress, and view a visual representation of the completed part. Please note that you must load a job file to the printer and select the file to be built before the job's details will be displayed within the Build page.

The Build page also contains the Notifications Display. Depending on the state of the printer a variety of notifications/warnings will be displayed within this area of the page. Touching the text on the screen will open a dialog indicating the reason(s) for the notification, and in some cases, steps to correct the notification. Once all notifications have been corrected, press the **Close** button within the dialog to exit the dialog.

To access the Build page, press the **Build** button within the Navigation Menu; a screen similar to the following figure will be displayed.

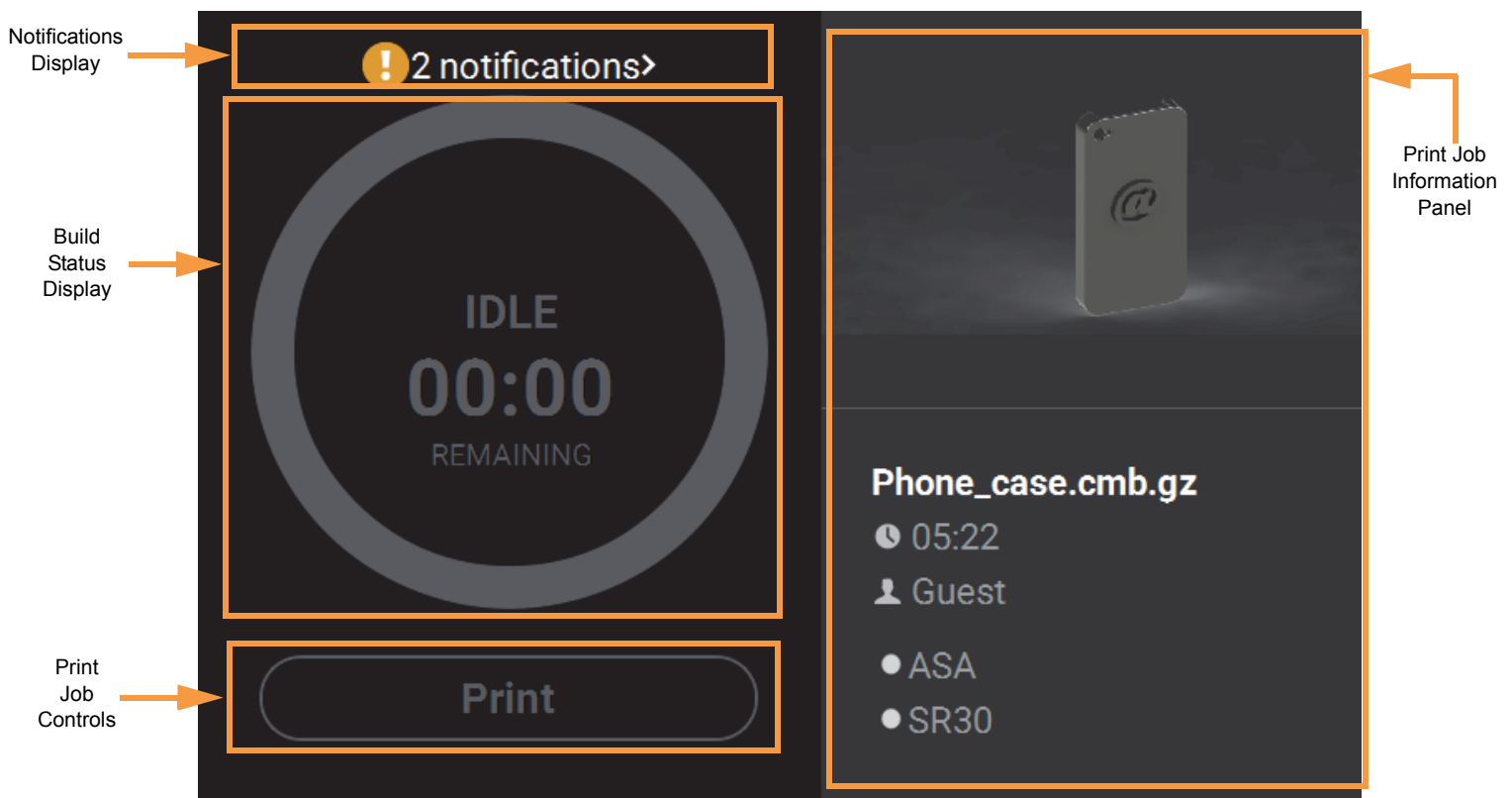

Notification Details

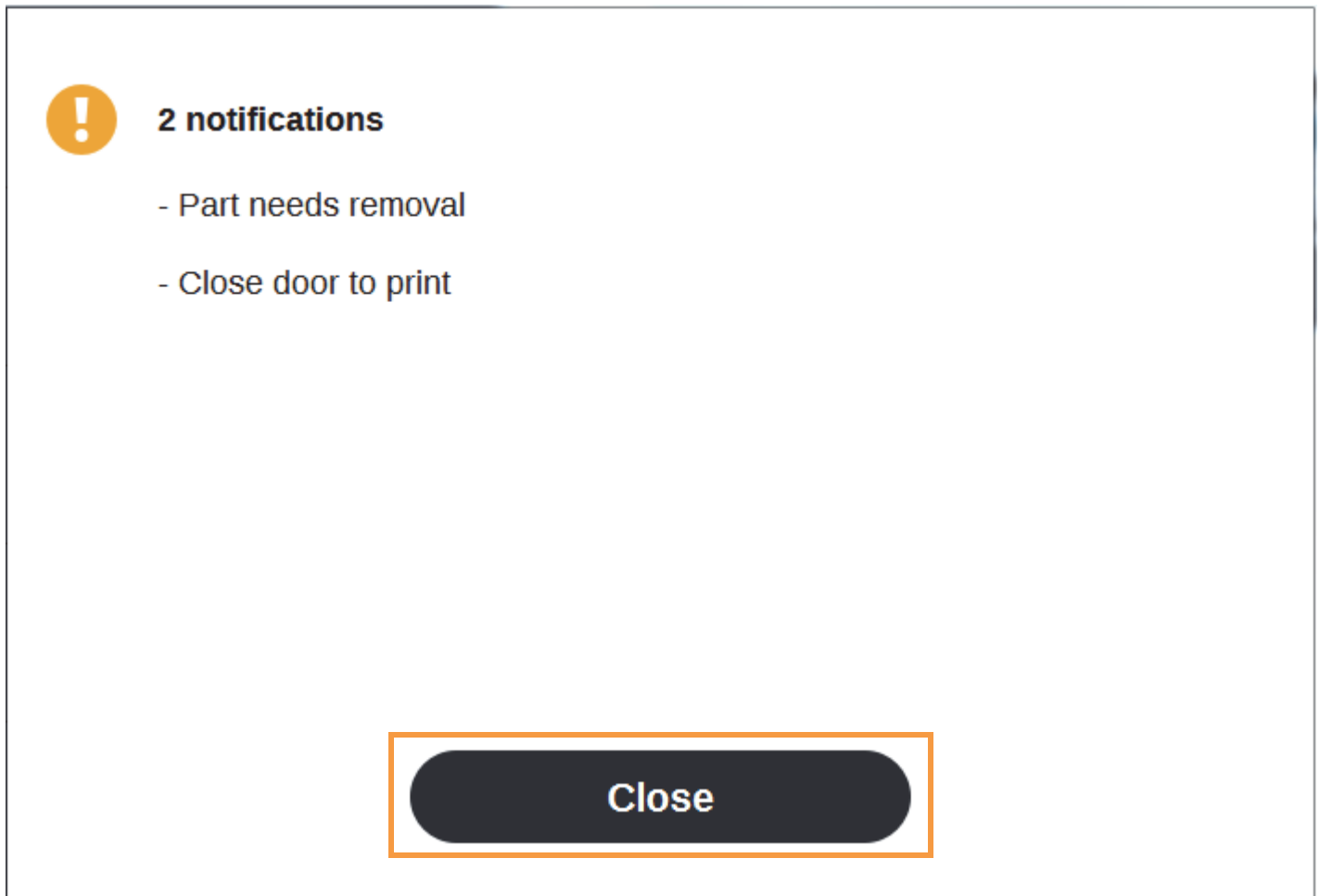

LOADING A FILE



Note: A job file must be loaded onto the printer and selected for building before the job's details will be displayed within the Build page.

The Print Job Information Panel is empty upon initial startup and the Build Status Display reflects its idle state. When there are no job files available within the Job Queue, the **Load File** button will be displayed within the Build page. Visibility of this button is dependent upon the method used to load job files to the printer.

A job must be selected for building before the job's details will be displayed within the Build page. In order to build a job, you must first load the job's corresponding job file to the printer. Job files can be loaded via network transfer (Ethernet or Wi-Fi) using the GrabCAD Print application on your workstation PC or by plugging a USB flash drive into one of the printer's USB ports and navigating to the job file via the Queue page. The job file you wish to build must be the first item listed in the Job Queue. Job files can be sorted as needed within the Queue page allowing you to select the job you'd like to build.

- If you send a single job file to the printer via network transfer using GrabCAD Print, the job's details will automatically be displayed within the Build Status Display once the job file is received by the printer, as this job will be the only item in the Job Queue. The Load File button will be hidden from view once the job file is received by the printer via network transfer.
- If you send two or more job files to the printer via network transfer using GrabCAD Print, the job details of the first file sent will automatically be displayed within the Build Status Display once the job file is received by the printer, as jobs are built in the order they're sent to the printer. The Load File button will be hidden from view once the first job file is received by the printer via network transfer.

- If you do not send files to the printer using GrabCAD Print and instead plug a USB flash drive into one of the printer's USB ports, the Load File button will be visible within the Build page. You can use this button to select a single job file you'd like to build directly from the flash drive.



Note: The Load File button within the Build page allows you to quickly select a single file to build off of a USB flash drive. The selected file will automatically be queued for building.

To load a file:

1. Plug a USB flash drive into one of the available USB ports on the front of the printer.
2. Press the **Load File** button within the Build page.



3. The Load File page will be displayed; press the **USB** button within this page.

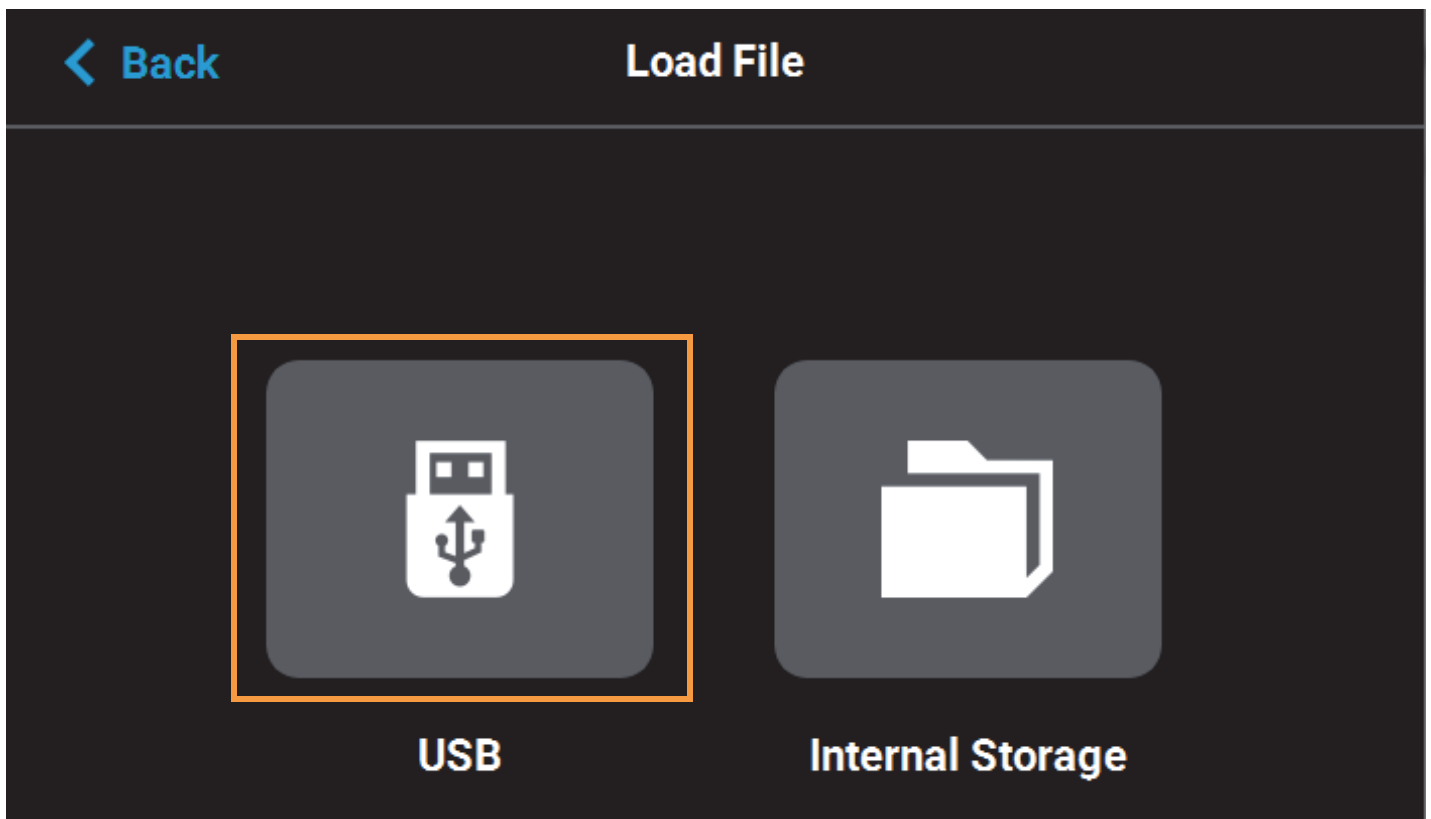

4. The Load File page will display the contents of the USB flash drive. Locate the desired job and select it by touching its row on the screen; doing so will open its Job Details page.



Note: If both USB ports contain a flash drive individual folder graphics will be displayed on the screen representing each flash drive and its contents. Touching the folder graphic on the screen will drill down into the folder and display its contents. If a single flash drive is installed the job files located on the flash drive will be displayed in individual rows.

5. Within the Job Details page press the **Add to Queue** button; this will load the job into the Job Queue.

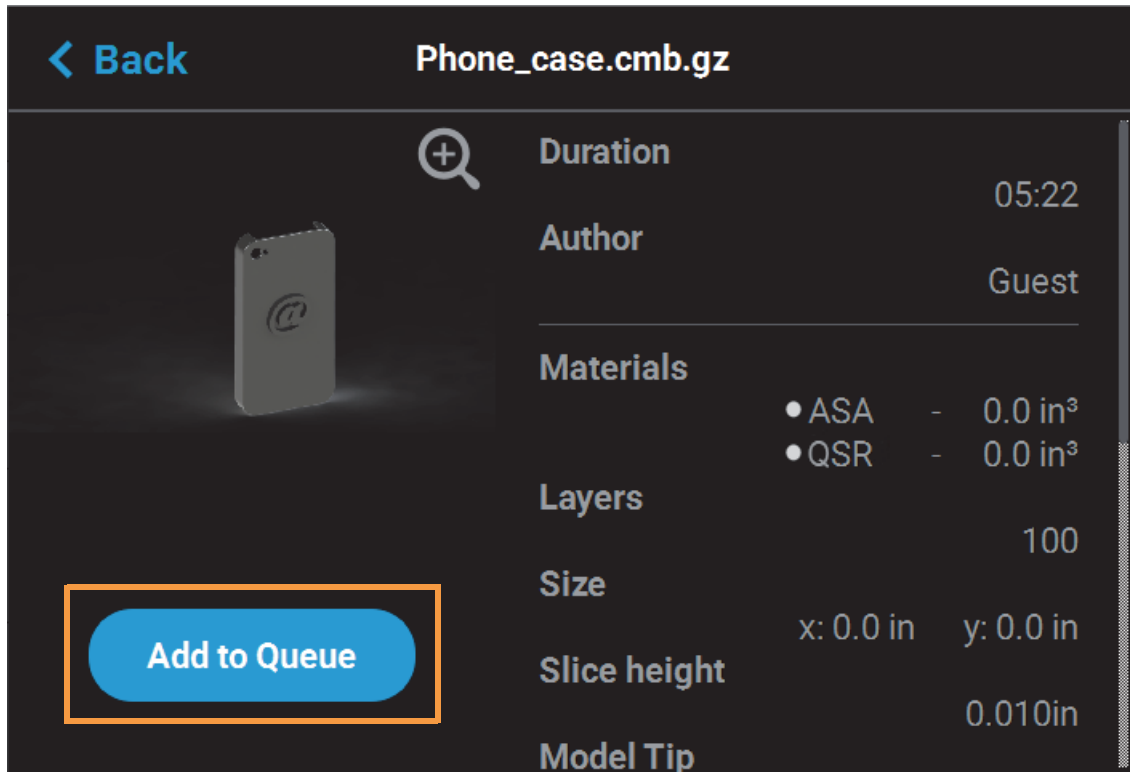

6. After pressing the Add to Queue button you will be returned to the Build page. The Load File button will no longer be visible. Instead, the details of the selected job file will be displayed within the Print Job Information Panel.
7. Pressing the **Print** button within the Build page will initiate the build. Build progress will be displayed within the Build Status Display.

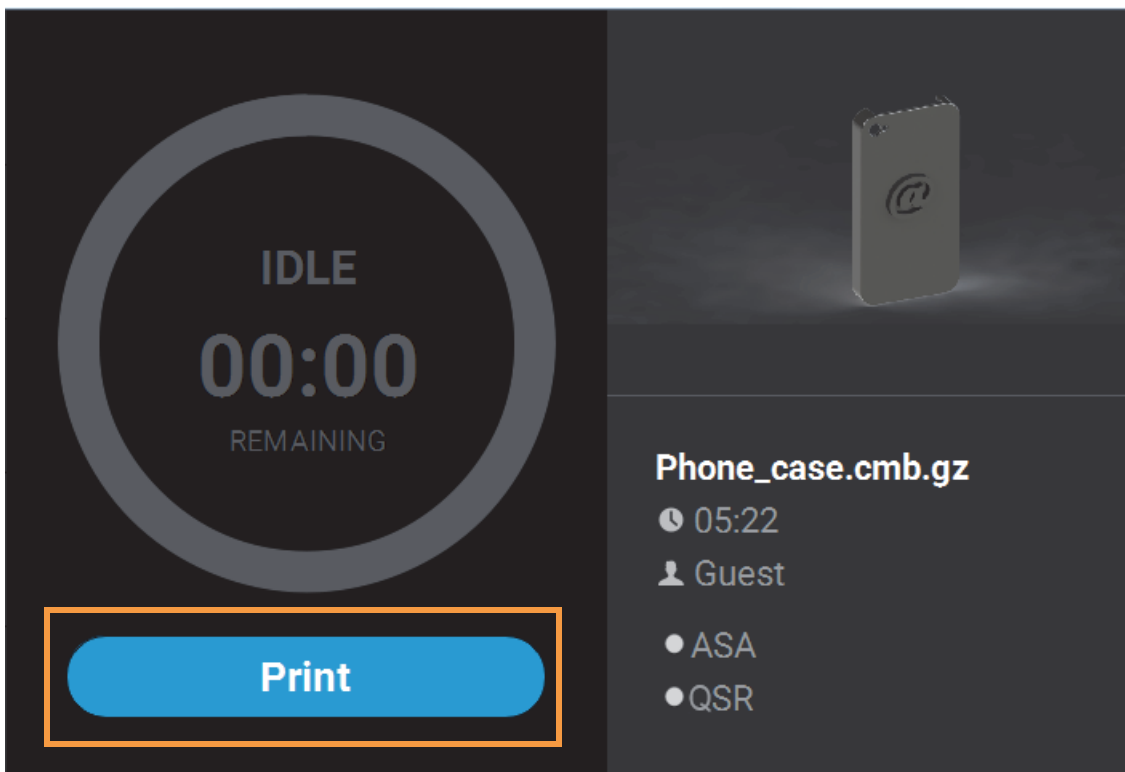

BUILD STATUS DISPLAY

The Build Status Display section of the Build page is composed of a two-part graphic. The center portion provides information on a selected and/or building job while the outer progress ring corresponds with the build information displayed; the information displayed will vary depending on the state of the printer.

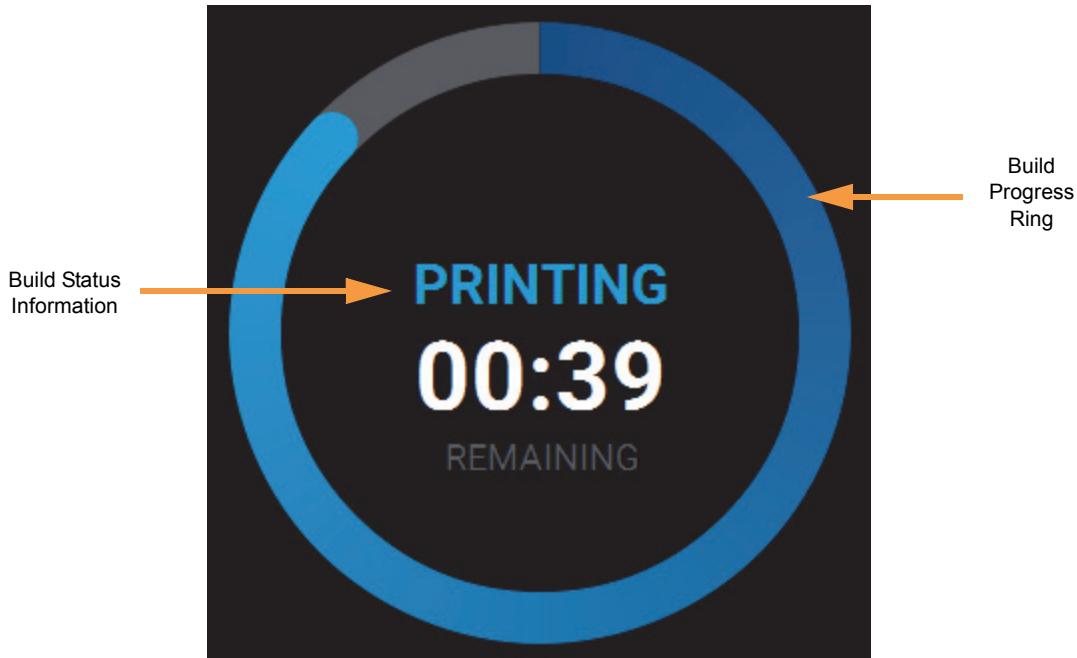

IDLE

When the printer is idle, "IDLE" will be displayed within the center of the Build Status Display. This indicates that the printer is in a state where it is ready to start a build. No progress is indicated within the outer build progress ring and the time remaining is displayed as zero.



BUILDING



Note: A job file must be loaded onto the printer and selected for building before build information will be displayed within the Build Status Display.

After pressing the **Print** button to start a build, "PREPARING" is briefly displayed within the Build Status Display, and the outer progress ring will fill, in gray, in a clockwise direction. This indicates the amount of time the printer requires to prepare for the start of the build, including the amount of time required for a Z Zero Calibration to occur.

Once build preparation is complete, "BUILDING" will be displayed within the center of the Build Status Display along with the amount of time remaining until the build is complete. As build progress is made, the amount of time remaining will get smaller until zero is reached, indicating that the build is complete. The build's percentage of completion is also displayed by radially filling in the outer progress ring, in blue, in a clockwise direction.

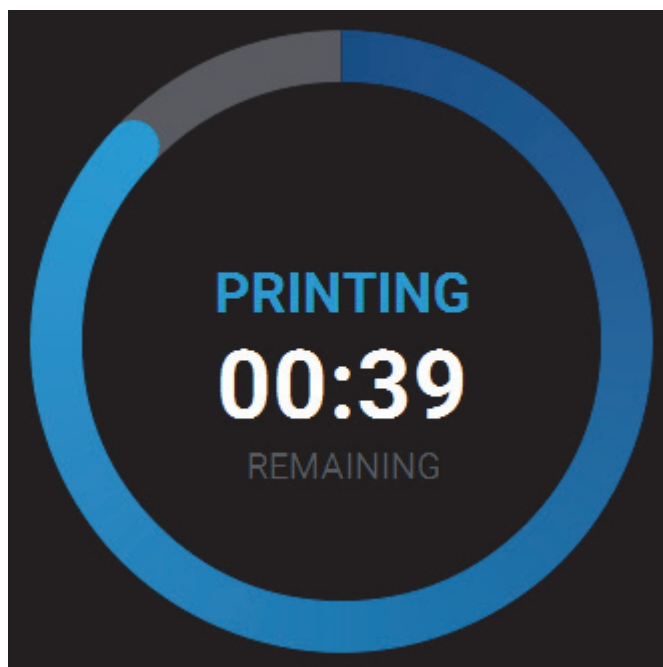
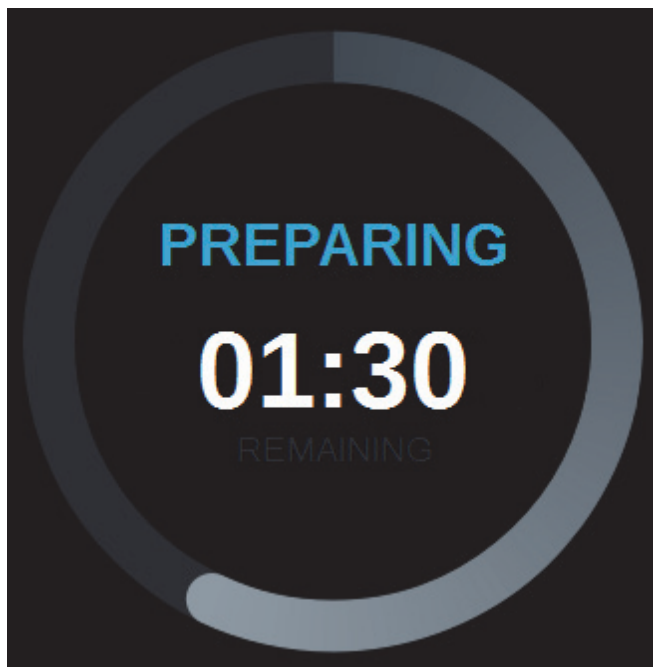

Touching the screen within the center of the Build Status Display while a part is being built will toggle the information displayed. After touching the screen the time estimation information will be hidden from view and instead the Build Status Display will show the number of completed layers as compared to the total number of layers in the build. Touching the screen again, will toggle back to the time estimation information displayed initially.

PRINT JOB CONTROLS

A button is displayed within the Build page, just beneath the Build Status Display. This button is used to start, pause, or abort a build, depending on the status of the printer. The Print button option will become selectable after you've performed the steps necessary to load a file and the printer is in a state where it is ready to build a part. This button will toggle to display the Pause and Abort button options when a build is in process.



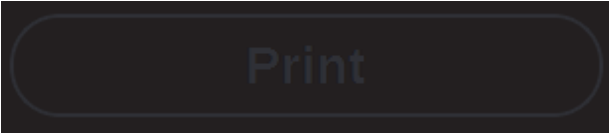

PRINT BUTTON

The Print button allows you to start a build (see [“Selecting a Job to Build”](#) on page 120 for more information). The Print button can appear in the following states:

Button State	Description
	Printer is in a buildable state AND a selected job is available to build. Selecting the Print button will begin the build.
	Print button is disabled and not selectable. Printer is not in a buildable state OR a job is not selected/available to build (i.e. queue is empty). To troubleshoot this issue, touch the text displayed on the screen within the Notifications Display. This will open a dialog allowing you to view the reason(s) for the current build state, including any issues impeding your ability to start a build (i.e. no substrate, etc.). See “Warnings at Build Start” on page 198 and “Errors Preventing a Build from Starting” on page 200 for more information.



PAUSE BUTTON

The Pause button allows you to pause an active build. The Pause button can appear in the following states:

Button State	Description
	<p>Printer is actively building. Selecting the Pause button in this state will pause the build.</p> <p>When the printer is paused, "PAUSED" is displayed within the Build Status Display.</p>
	<p>Pause button is disabled and not selectable.</p> <p>Printer is preparing for a build, there is no job currently building on the printer.</p>
	<p>Printer is paused. The Pause button toggles to display the Play button.</p> <p>Selecting the Play button will resume the build.</p> <p>If the build was automatically paused as the result of an error, a notification will be indicated on the screen. Touching the notification text displayed will provide additional details pertaining to the current build state. See "Build Warnings" on page 122 and "Build Pause Warnings" on page 205 for more information.</p>

ABORT BUTTON

The Abort button allows you to abort an active build. The Abort button can appear in the following states:

Button State	Description
	<p>Printer is actively building.</p> <p>Pressing the Abort button in this state will initiate an abort of the build and will display a prompt asking you to acknowledge the abort.</p> <ul style="list-style-type: none">- If accepted, the build will be aborted.- If canceled, the build will be unaffected (i.e. revert to its previous state).
	<p>Abort button is disabled and not selectable.</p> <p>There is no job currently building on the printer.</p>

QUEUE PAGE

The Queue page contains the list of files (jobs) which have been downloaded to the printer and are queued for building; this list is referred to as the Job Queue. By default, jobs are added to the Job Queue in the order they were sent to the printer via GrabCAD Print and/or transferred from a USB flash drive. Individual jobs are listed in numbered rows with row one corresponding to the first job in the Job Queue. Each row displays the name of the job, estimated build time for the job, and name of the user that submitted the job. From the Queue page you can add files to the Job Queue, select a file to build, sort jobs within the Job Queue, view additional details associated with a selected job, and access the Sample Queue.

To access the Queue page, press the **Queue** button within the Navigation Menu; a screen similar to the following figure will be displayed. Please note that the Job Queue is empty upon initial startup.

The heading of the Queue page lists the number of jobs currently loaded into the Job Queue. Up to three jobs are displayed within the Job Queue list at a given time. If the Job Queue contains more than three jobs, use the scrollbar (to the right of the Job Queue list) to scroll up or down through the list of available jobs.

Pressing the **Edit** button within the heading of the page will display the Job Queue Control buttons; these buttons allow you to sort and /or delete the jobs within the Job Queue as needed. Pressing the **Load File** button within the heading of the page will allow you to add additional files to the Job Queue. Touching one of the rows listed within the Job Queue will open that job's Job Details page; this page contains additional information pertaining to the selected job (material configuration, tip size, etc.). After selecting either of these buttons or opening a job's details page a "Back" button will be displayed within the heading of the page; press this button to return to the main Queue page.

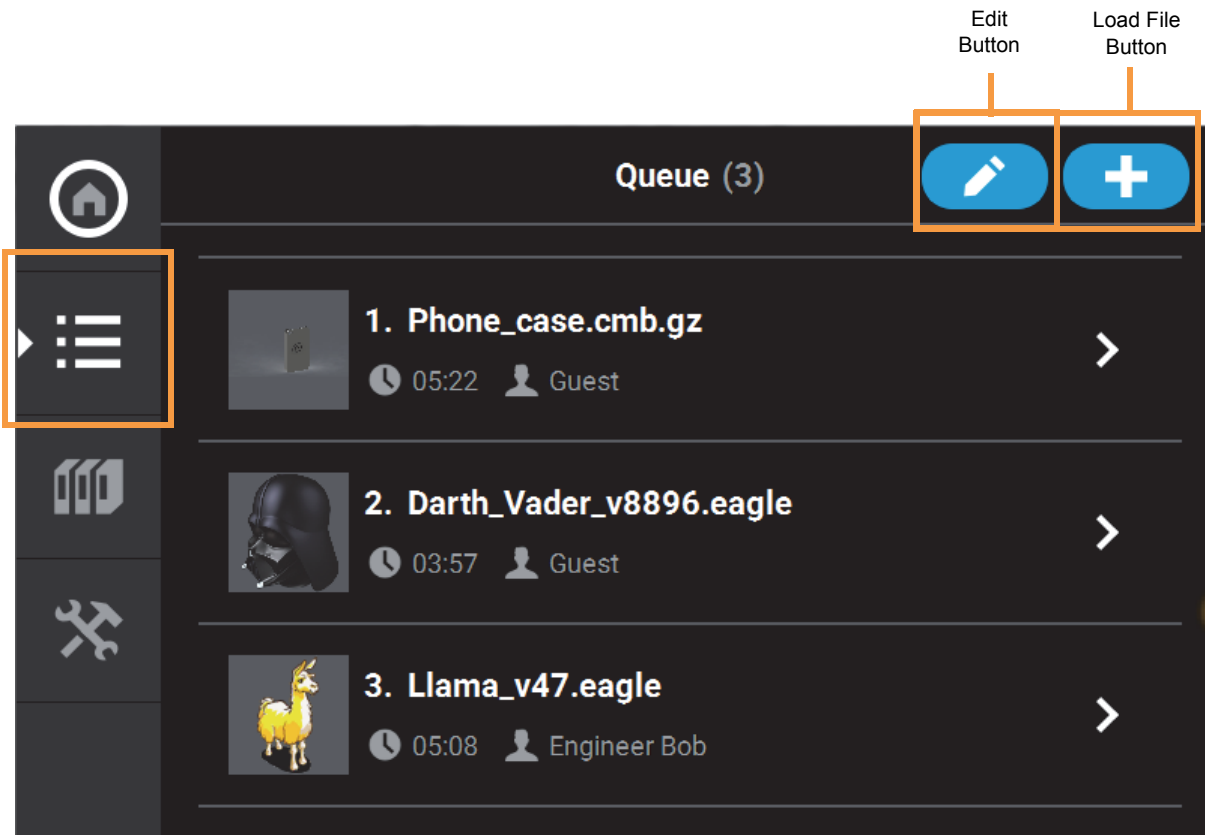

ADDING A JOB TO THE JOB QUEUE

The Job Queue is empty by default. To populate the Job Queue you must first load individual job files to the Job Queue using one of two methods:

1. Network transfer via the GrabCAD Print application on your workstation PC. This is the preferred method for adding jobs to the Job Queue.
2. USB method via a USB flash drive inserted into one of the available USB ports on the front of the printer. This method can be used as a backup to the GrabCAD Print method if you are unable to transfer job files to the printer via your Ethernet connection (due to poor connectivity, a network outage, etc.) or Wi-Fi connection. This method also provides a convenient option for you to reprint a common job, as you can store the processed job file on the USB flash drive and access it repeatedly.

GRABCAD PRINT METHOD

As part of the printer's installation and setup process, you should have downloaded and installed the GrabCAD Print application onto your workstation PC. GrabCAD Print is the software used to process job files and then transfer them to the printer (via your facility's Ethernet connection or via Wi-Fi) to be built.

Jobs are sent to the printer in CMB format and are placed directly into the Job Queue. No additional steps are required to add a job to the Job Queue when sending job files directly to the printer via GrabCAD Print. After sending the job file to the printer navigate to the Queue page by pressing the **Queue** button within the Navigation Menu. The transferred job file will be displayed within the Job Queue list. Jobs will appear within the Job Queue in the order they're sent to the printer from GrabCAD Print. To build a specific job, that job must be listed as the first item in the Job Queue. You can sort jobs within the Job Queue as needed to select the job you'd like to print.

USB METHOD

The printer features three USB ports. A USB flash drive can be inserted into any of these ports and job files contained on the flash drive can be added to the Job Queue. Please note that job files must be processed using GrabCAD Print before they are placed onto the flash drive and subsequently added to the Job Queue. Once the flash drive is plugged into one of the printer's USB ports, you will need to perform the following steps to add the desired job file to the Job Queue:

1. Plug a USB flash drive into one of the available USB ports on the printer.
2. Navigate to the Queue page by pressing the **Queue** button within the Navigation Menu.

3. Press the **Load File** button in the upper-right corner of the touchscreen.

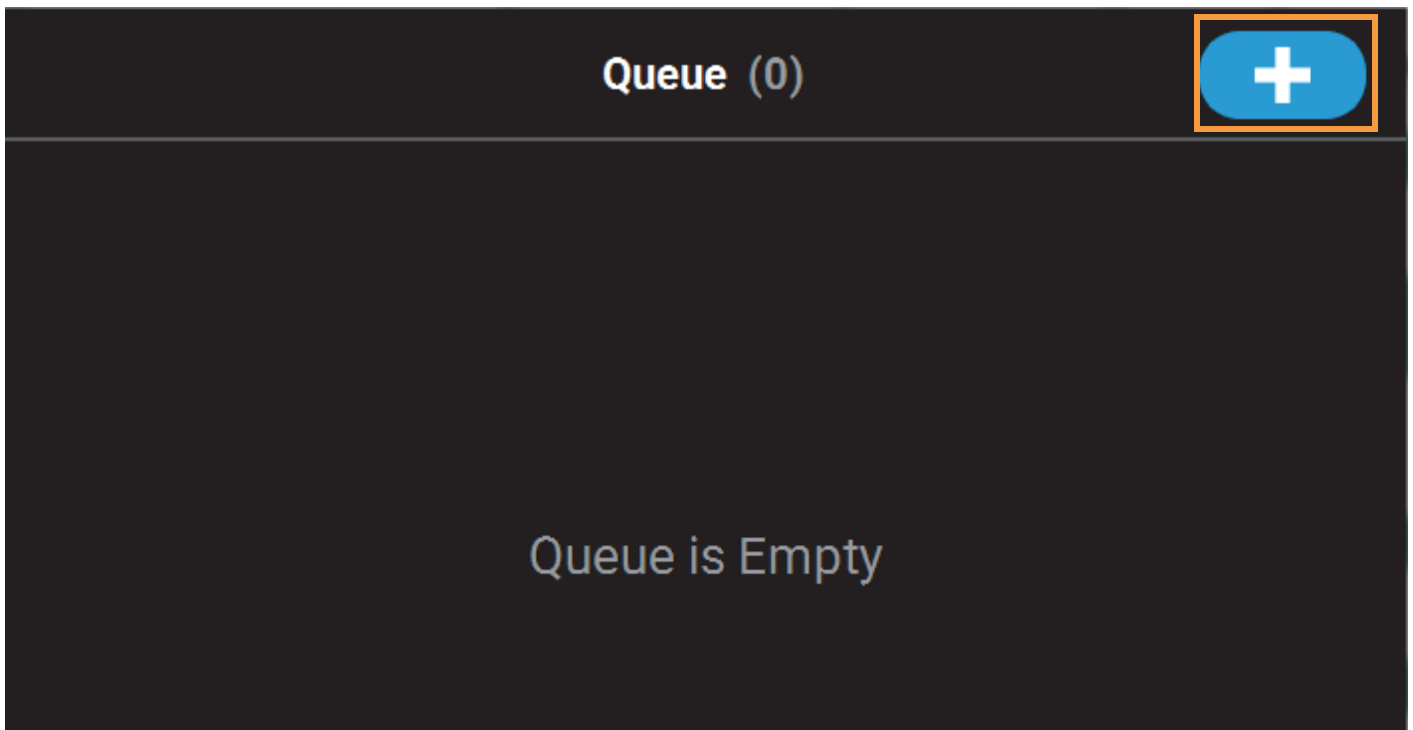

4. The Load File page will be displayed; press the **USB** button within this page.

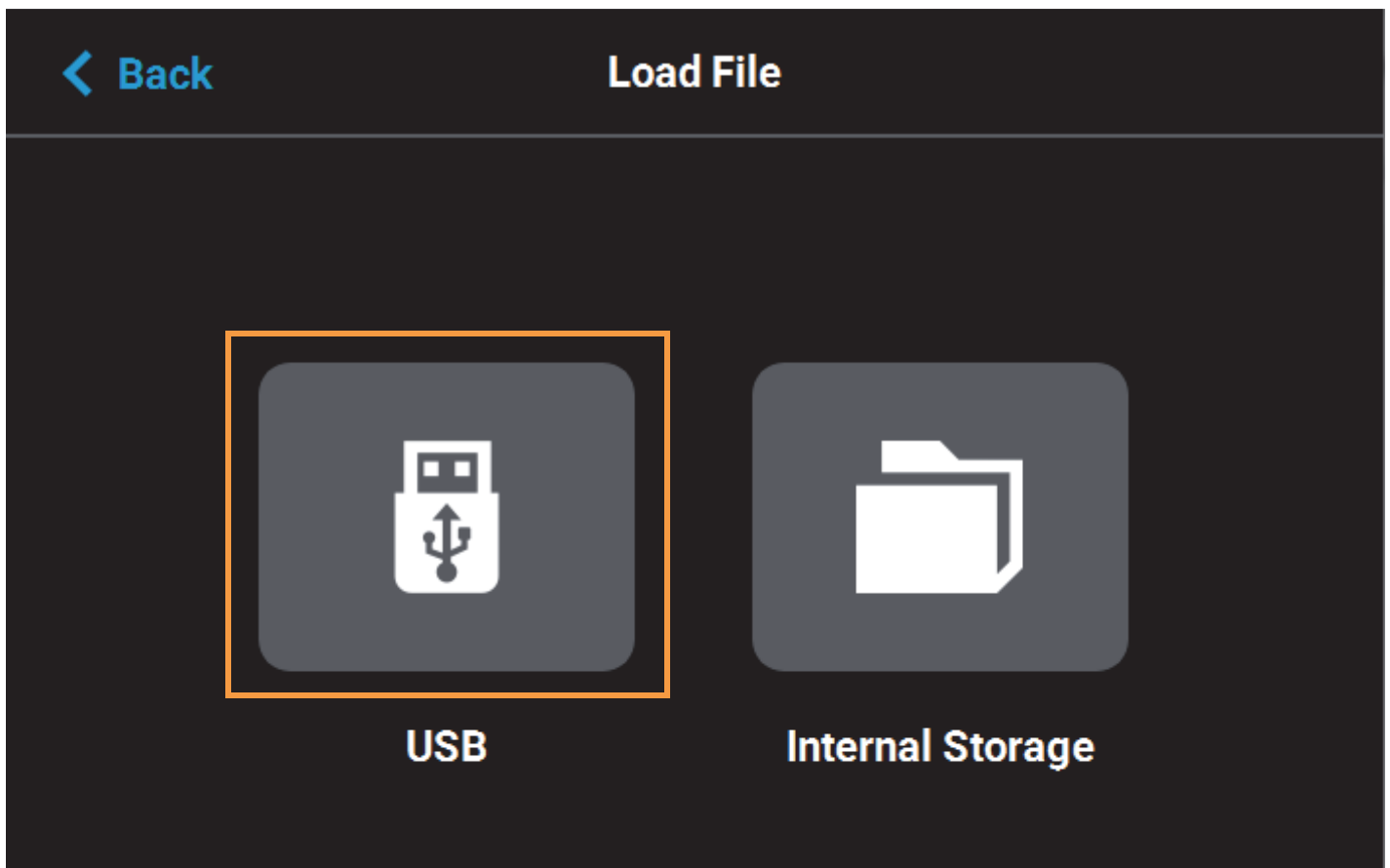

5. The Load File page will display the contents of the USB flash drive. Locate the desired job and select it by touching its row on the screen; doing so will open its Job Details page.



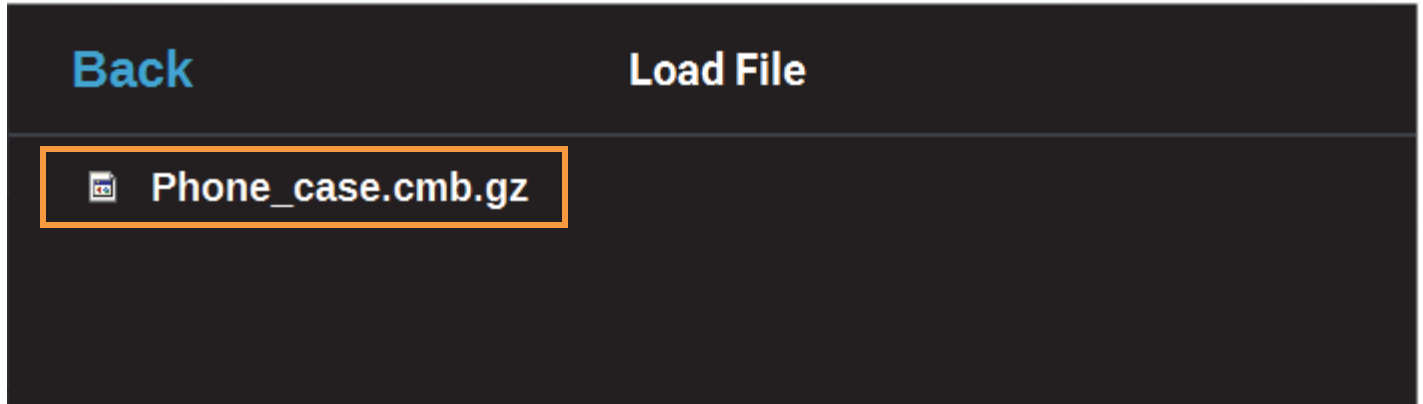

Note: If any USB port contain a flash drive, individual folder graphics will be displayed on the screen representing each flash drive and its contents. Touching the folder graphic on the screen will drill down into the folder and display its contents. If a single flash drive is installed the job file(s) located on the flash drive will be displayed in individual rows.



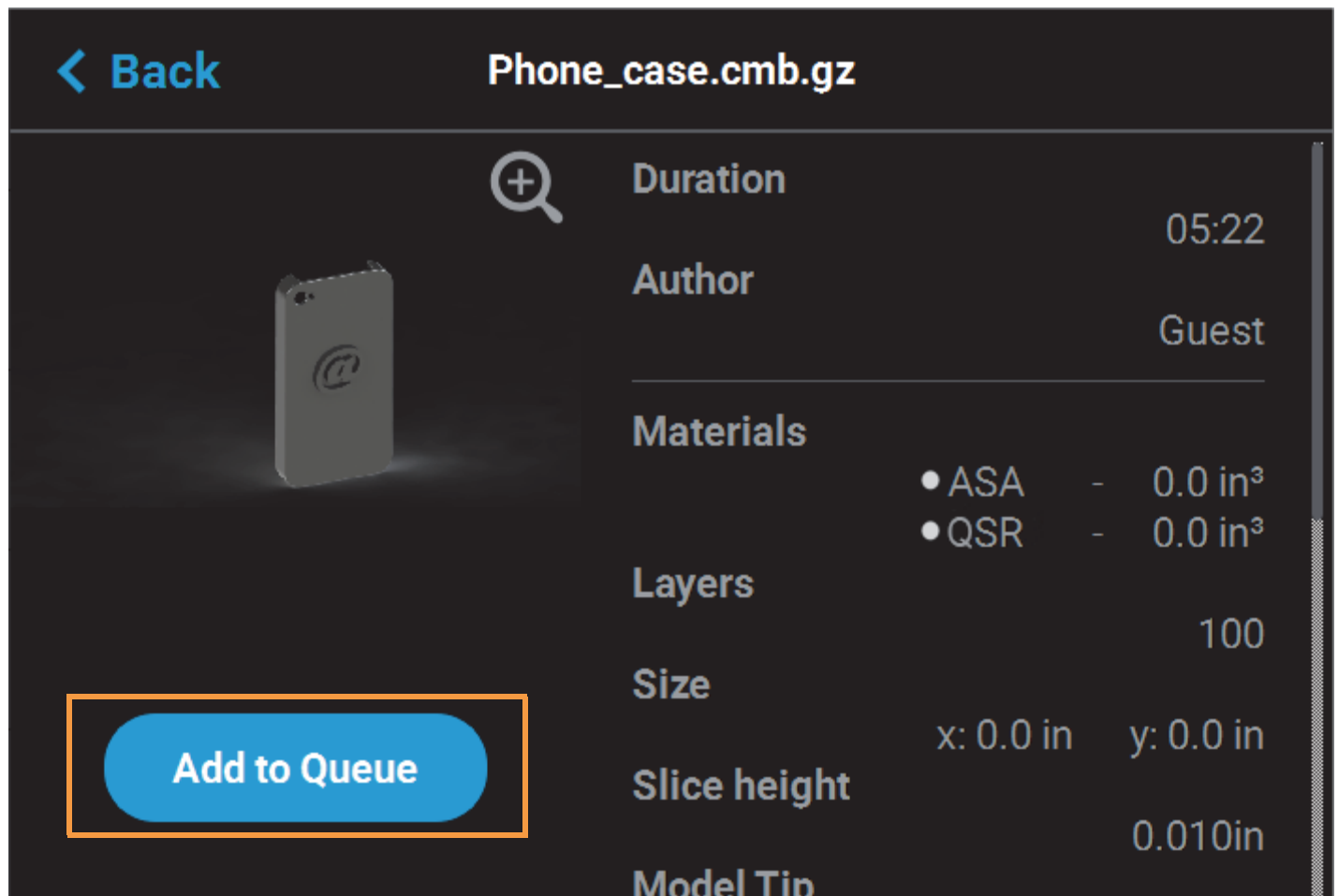



6. Within the Job Details page press the **Add to Queue** button; this will load the job into the Job Queue.







- The file will load into the Job Queue. Once loading is complete the file will be added to the Job Queue list.



Queue (1)  

 **1. Loading...** 

 Unknown  Unknown

Queue (1)  

 **1. Phone_case.cmb.gz** 

 05:22  Guest

EDITING THE JOB QUEUE

By default, jobs are built in the order in which they appear within the Job Queue. To build a specific job, that job must be listed as the first item in the Job Queue. Pressing the **Edit** button within the Queue page will open the Edit Queue page. Using the Job Queue Control buttons found within this page you can sort and /or delete the jobs within the Job Queue as needed, to ensure the job you wish to build is the first item listed within the Job Queue.

Pressing the **Back** button will allow you to exit the Edit Queue page and return to the main Queue page.

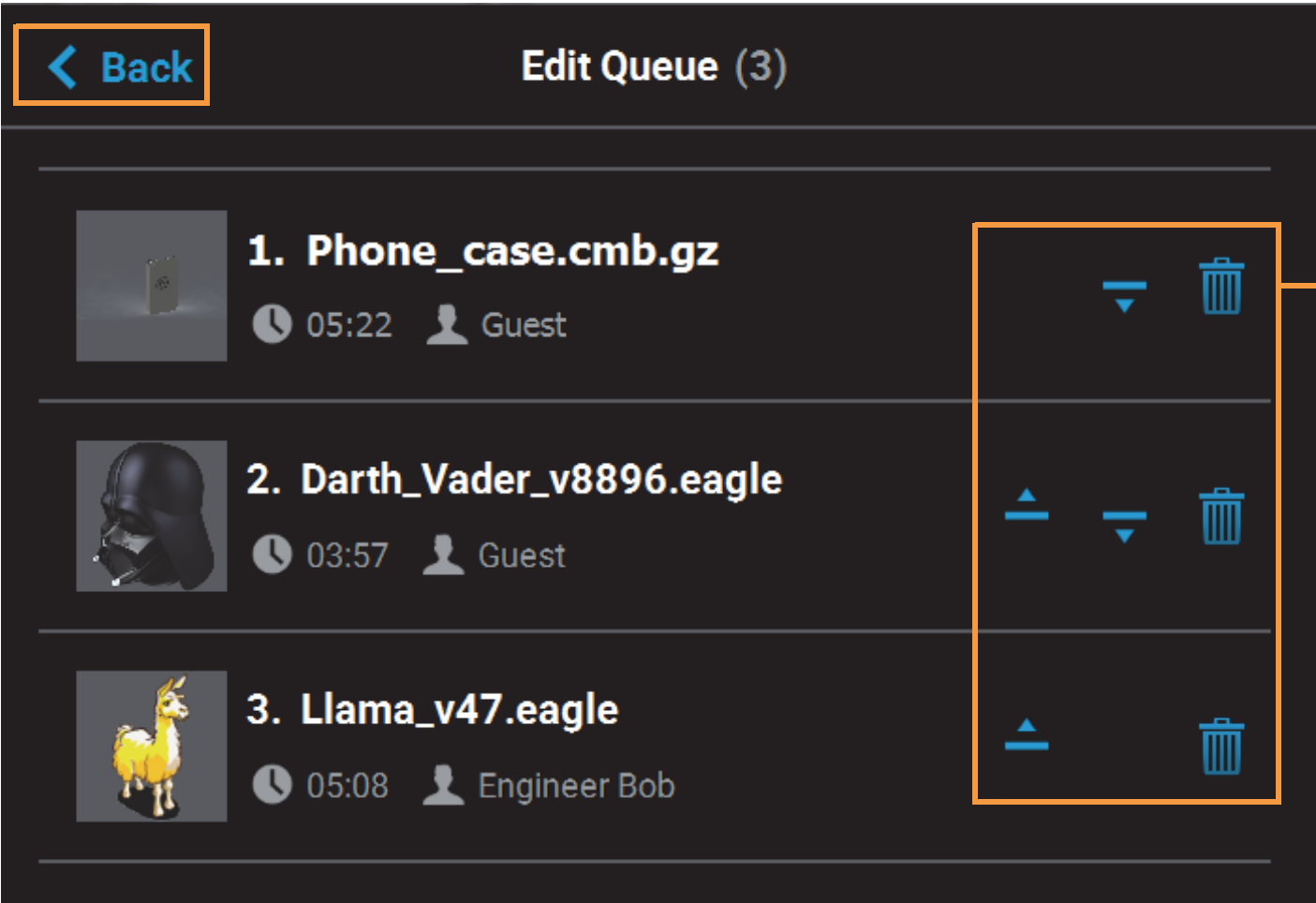





The screenshot displays the 'Edit Queue (3)' interface. At the top left, there is a blue 'Back' button with a left-pointing arrow. The title 'Edit Queue (3)' is centered at the top. Below the title, three job entries are listed, each with a thumbnail image, a title, a duration, and a user name. To the right of each job entry is a set of control buttons: a downward arrow for moving down, an upward arrow for moving up, and a trash can icon for deleting. The first job, '1. Phone_case.cmb.gz', has a duration of 05:22 and is by 'Guest'. The second job, '2. Darth_Vader_v8896.eagle', has a duration of 03:57 and is by 'Guest'. The third job, '3. Llama_v47.eagle', has a duration of 05:08 and is by 'Engineer Bob'. A label 'Job Queue Controls' with a line pointing to the control buttons is located on the right side of the interface.

Job ID	Thumbnail	Title	Duration	User	Move Up	Move Down	Delete
1	Phone_case.cmb.gz	1. Phone_case.cmb.gz	05:22	Guest		▼	🗑️
2	Darth_Vader_v8896.eagle	2. Darth_Vader_v8896.eagle	03:57	Guest	▲	▼	🗑️
3	Llama_v47.eagle	3. Llama_v47.eagle	05:08	Engineer Bob	▲		🗑️

JOB QUEUE CONTROLS

After opening the Edit Queue page three Job Queue Control buttons will be displayed within each row of the Job Queue list (one set of buttons per entry in the list). These buttons will allow you to rearrange the jobs in the Job Queue as needed. These buttons have the following functionality:

Name	Button States	Description
Move Up	 Selectable	When selectable, moves the selected job up one position in the job Queue list.
	 Disabled	To move a job to the top of the Job Queue list, press this button repeatedly until the job appears at the top of the list. There is not an option to move a job directly to the top of the list.
Move Down	 Selectable	When selectable, moves the selected job down one position in the Job Queue list.
	 Disabled	To move a job to the bottom of the Job Queue list, press this button repeatedly until the file appears at the bottom of the list. There is not an option to move a job directly to the bottom of the list.
Delete	 Selectable	Removes the selected job from the Job Queue list. You will not be asked to confirm this action prior to the job being deleted from the Job Queue.

VIEWING JOB DETAILS

To view additional details regarding a particular job in the Job Queue, select the desired job by touching its row on the screen. Doing so will open its Job Details page; this page displays the following:

- Duration: amount of time required to complete the build.
- Author: name of the user that submitted the job.
- Materials: model and support materials associated with the job.
- Layers: number of layers in the job.
- Slice height: slice height associated with the job.
- Version: Insight version that the part was compiled with.

Use the scrollbar (along the right side of the page) to scroll up or down within the page. To close this page and return to the main Queue page, press the **Back** button within the header of the page.

Phone_case.cmb.gz

Duration 05:22

Author Guest

Materials

- ASA - 0.0 in³
- QSR - 0.0 in³

Layers 100

Size x: 0.0 in y: 0.0 in

Slice height 0.010in

Model Tip

Print

The left portion of the Job Details page displays a visual representation of what the part will look like once the build is complete.

Pressing the **Zoom In** button  within the upper-right corner of this portion of the page will hide the job details information and instead zoom in on the representation of the completed part.

Press the **Zoom Out** button in the upper-right corner of the expanded view display to close the expanded view and return to the Job Details page.



ABOUT THE SAMPLE QUEUE

The printer comes with several sample job files permanently installed on its hard drive. These files are accessible via the Sample Queue. This queue is composed of a few sample part files as well as a variety of other files that are helpful for testing the printer. The majority of the files within the Sample Queue will be utilized only by authorized service representatives when performing maintenance on the printer. To access the Sample Queue:

1. Navigate to the Queue page by pressing the **Queue** button within the Navigation Menu.
2. Press the **Load File** button in the upper-right corner of the touchscreen.
3. The Load File page will be displayed; press the **Internal Storage** button within this page. The list of sample jobs contained within the Sample Queue will be displayed.

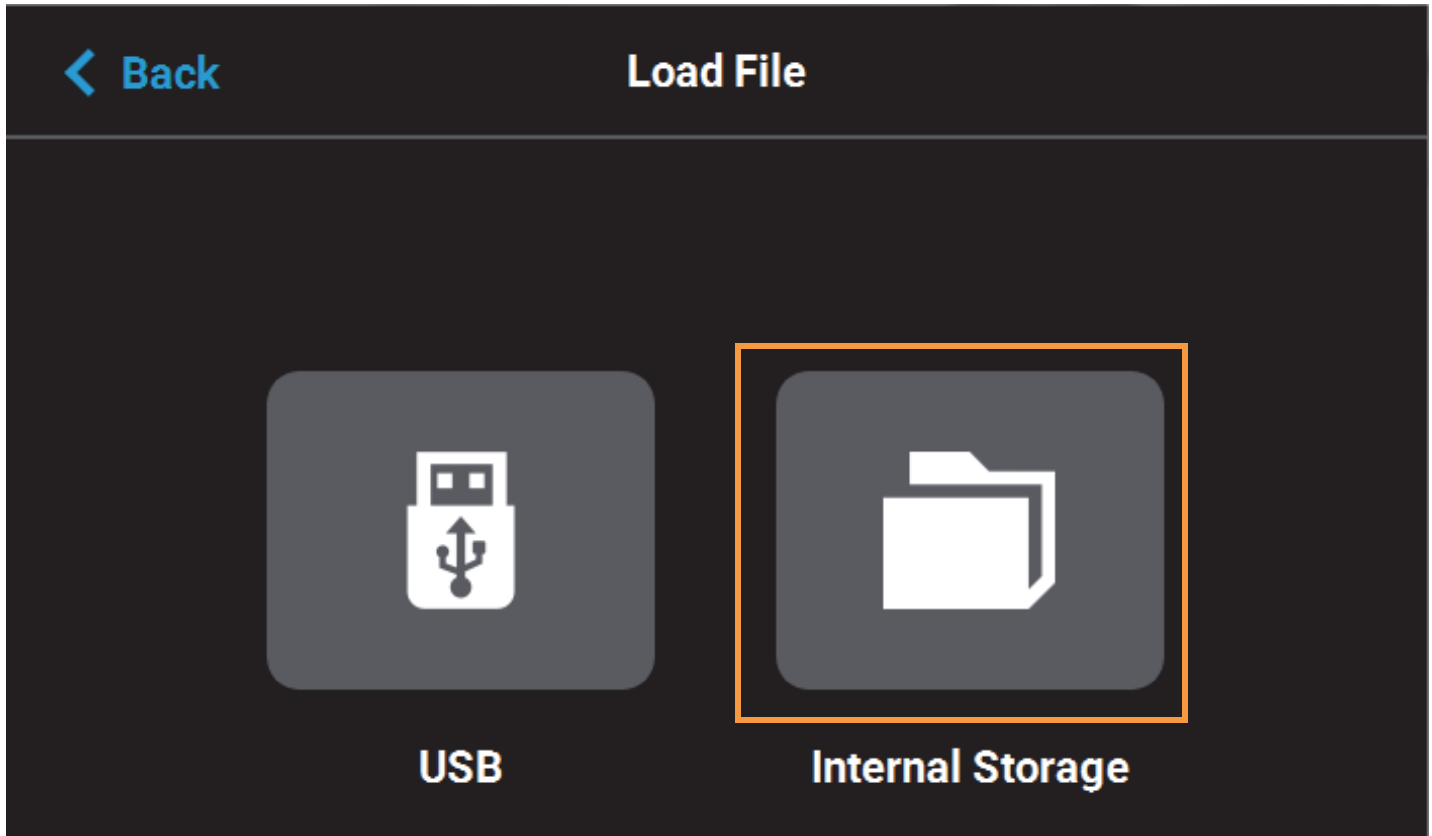

Overall, the functionality of the Sample Queue is the same as that of the Job Queue:

- Additional details for a job can be viewed by opening its Job Details page.
- Within the Job Details page you can view the specifics of the job including build time, author, material requirements, number of layers, slice height, and Insight version that the job was compiled with.
- Pressing the Zoom In button within the page will provide a detailed view of what the job will look like once it has been successfully built. Pressing the Zoom Out button will close this view and return you to the Job Details page.
- Pressing the Print button within the Job Details page will select the job for building.

However, the following functionality differences exist for the Sample Queue:

- Job queue controls are disabled for the Sample Queue, and therefore these job files cannot be deleted.
- Jobs in the Sample Queue cannot be sorted.

MATERIALS PAGE

The Materials page displays a detailed representation of the printer's current materials configuration. Within this page you can view the printer's current materials configuration including material types and colors, view material spool volumes and load statuses, load and unload materials, view current and set point head temperatures, and perform a variety of head related maintenance functions.

To access the Materials page, press the **Materials** button within the Navigation Menu; a screen similar to the following figure will be displayed.

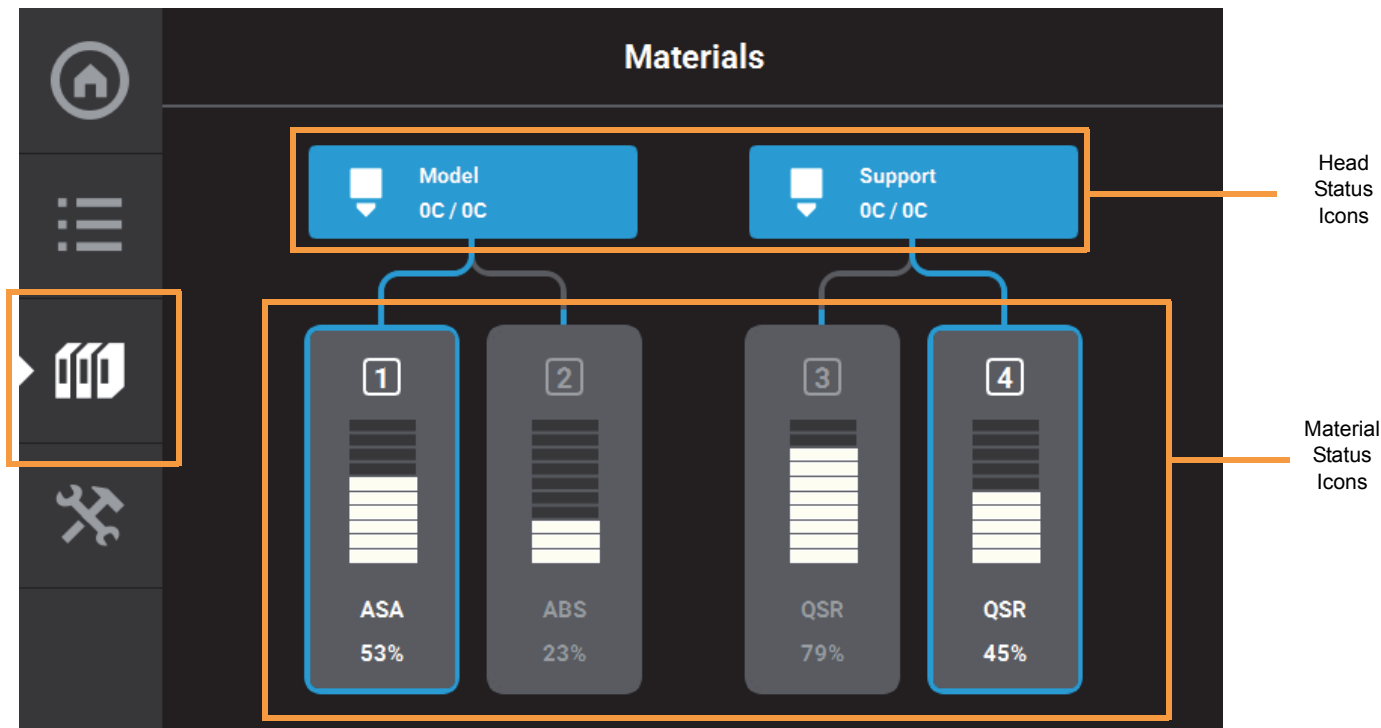

Two head status icons are displayed within the upper portion of the Display Area. These icons display load status information as well as the current temperature as compared to the set point temperature of each of the printer's heads (temperatures are predetermined and based on material type loaded to the head). The right-most icon pertains to the printer's support head while the left-most icon pertains to the printer's model head. Touching one of these icons on the screen will open that head's Head Details page; this page contains additional information pertaining to the selected head as well as a button for initiating a variety of head maintenance functions. Icons will be solid gray or solid blue depending on their status.

Depending on your printer's configuration, either two or four material status icons are displayed within the lower portion of the Display Area. These icons represent the model and support materials loaded/installed within the printer. The right-most icon(s) indicate(s) the status of the printer's support material while the left-most icon(s) indicate(s) the status of the printer's model material. These icons will take on a variety of colors and highlighted states depending on their status. Material spools selected for use for building, and whose material is loaded to the head, are indicated by a blue border. Touching one of these icons on the screen will open that material's Material Details page; this page contains additional information pertaining to the selected material as well as buttons for performing a material load or unload.

After selecting any icons or opening a details page a "Back" button will be displayed within the heading of the page; press this button to return to the main Materials page.

TOOLS PAGE

The options within the Tools page are organized into 6 categories: Settings, Calibration, Maintenance, Network, Power, and Light. The Display Area of the Tools page contains a button corresponding to each of these categories. With the exception of the Light button, pressing the button corresponding to each of these categories will open an individual page containing printer information that can be viewed as well as printer settings and preferences which can be configured for that particular category. After selecting any of the buttons within the Tools page a “Back” button will be displayed within the heading of the page; press this button to return to the main Tools page.



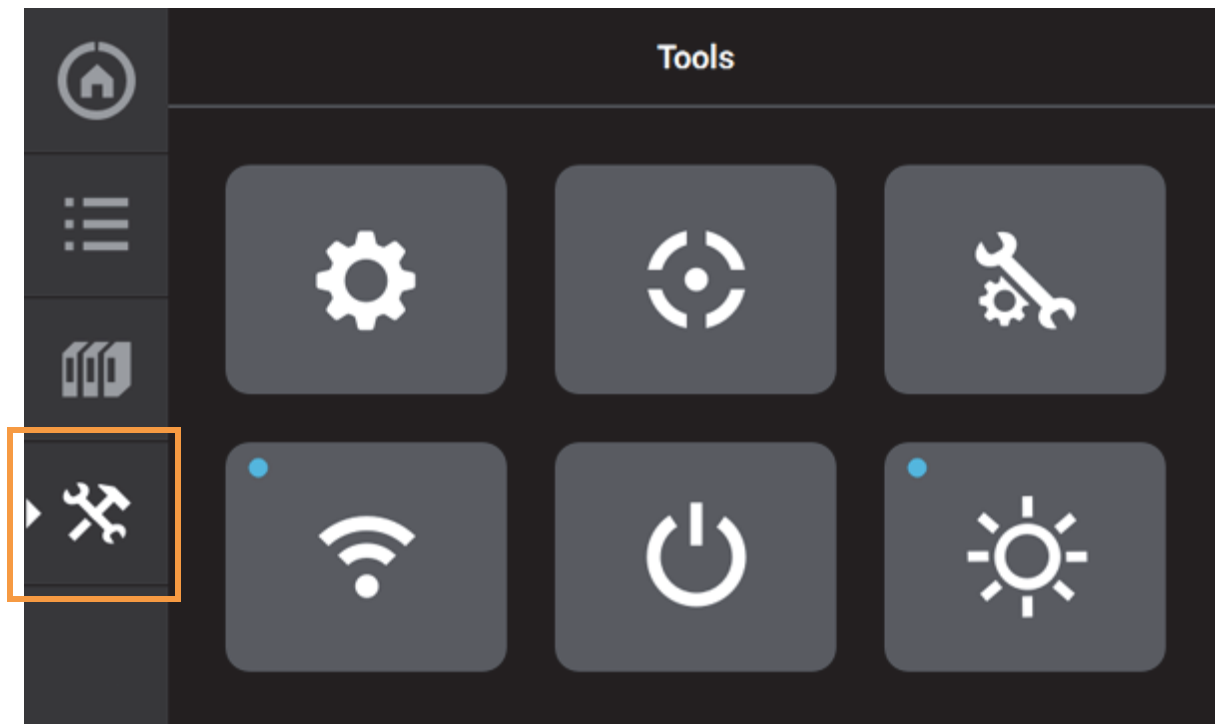

Within this page you can turn a variety of printer settings on/off (including part placement, standby mode, etc.), select your printer’s address type (dynamic, static, or Wi-Fi), adjust the brightness of the touchscreen display and turn the printer or the oven light on/off. As a part of its initial installation and setup (performed by your authorized service representative) your printer’s network settings will be configured within this page. Once those settings are configured you may need to occasionally access this page in order to adjust printer preferences.

To access the Tools page, press the **Tools** button within the Navigation Menu; a screen similar to the following figure will be displayed.

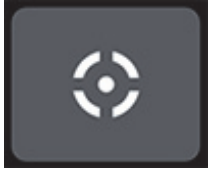

TOOLS PAGE MENU

The Display Area of the Tools page contains 6 buttons. With the exception of the Light button, pressing each of these buttons will open an individual page containing printer information that can be viewed as well as printer settings and preferences which can be configured.

Icon State	Description
 Settings	Pressing the Settings button opens the Settings page. From this page you can configure and adjust several of the printer's default settings.
 Calibration	Pressing the Calibration button opens the Calibration page. From this page you can preform various printer calibration procedures.
 Maintenance	Pressing the Maintenance button opens the Maintenance page. From this page you can perform various printer maintenance procedures.
 Network	Pressing the Network button opens the Network page. From this page you can configure the printer's network connection.
 Power	Pressing the Power button opens the Power page. From this page you can shutdown or restart the printer.
 Light	The Light button is the only option within the Tools page that does not open a new page after being pressed. Instead, the Light button allows you to turn the oven light ON and OFF. An indicator within the upper-left corner of the button displays the current state of the oven light (ON or OFF).

MATERIAL HANDLING

LOADING MATERIAL

The information within this section will walk you through the process of loading material to the model and support heads. As you complete the required steps, be sure to observe the status information displayed on the touchscreen.



Note: Loading material can only be done when the printer is stopped (idle) and is not building.

The Material Spool Preparation section describes the steps necessary to prepare a material spool for insertion into a material bay, and highlights the components of the material spool. Once a material spool has been prepared for use, the steps within the Material Spool Installation section will guide you through the process of installing a material spool and loading material to the head.

The F270 and F370 utilize four material bays - two model and two support, while the F170 utilizes two material bays - one model and one support. In order to build, at least one model and one support spool must be installed. If you know that a job will require more material than what is available on a single spool, you can install a second model and/or support spool into the corresponding vacant material bay in order to utilize the auto changeover feature, as applicable. However, it is recommended that you properly store spools that are not in use in order to safeguard against moisture exposure.

MATERIAL SPOOL PREPARATION

The process for preparing a new, unopened material spool varies slightly from the process for preparing a previously used material spool. When preparing a new (unopened) spool you will first need to remove the spool from its Stratasys packaging. When preparing a previously opened spool you will need to remove the spool from its storage bag. Once removed, pull the tail end of the spool's filament out of the filament tail capture location. Inspect the filament tail to ensure filament is not bent. If bent, cut the filament tail flush (using the 5" cutter included in the Welcome Kit). Refer to the following figure for material spool details.

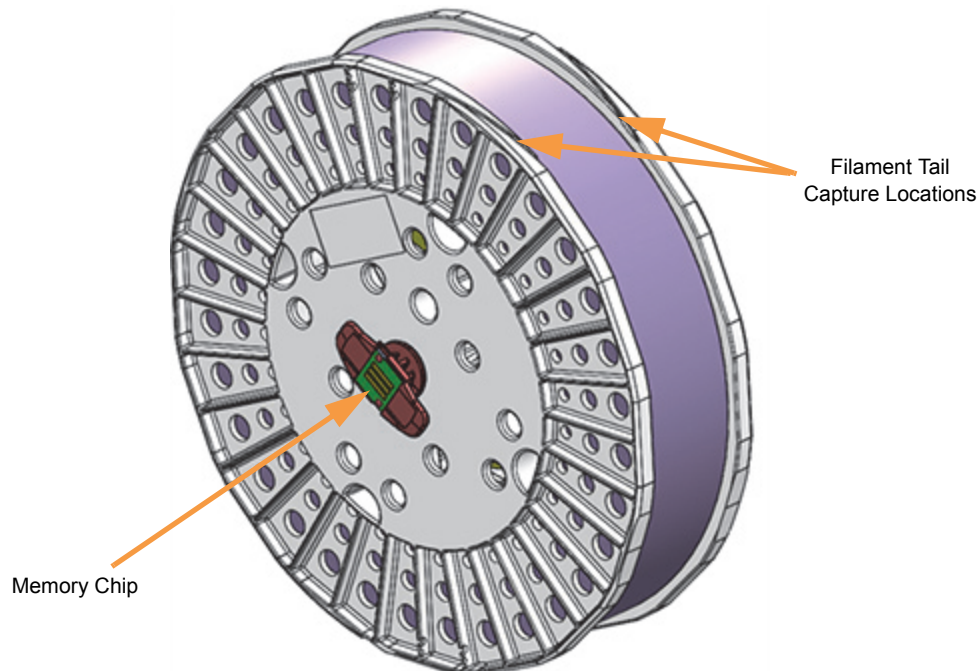

MATERIAL SPOOL INSTALLATION

Once you've properly prepared a material spool, you can begin the process of loading material. Pre-loading filament to the drive wheels places a spool's filament into position to be loaded to the liquefier tip within the head. Once filament is detected by the filament present switch, it can then be completely loaded to the liquefier tip.

To install and load a material spool:

1. Ensure that the printer is stopped (idle) and is not building.
2. Select the **Materials** button from the Navigation Menu; a screen similar to the following figure will be displayed. The information displayed represents the current configuration of your printer.
3. Observe the status information displayed for each of the Materials Status Icons. A Material Status Icon with a dashed gray border indicates that a material spool is not present in the material's corresponding material bay. A completely gray Head Status Icon indicates that material is not loaded to that head.

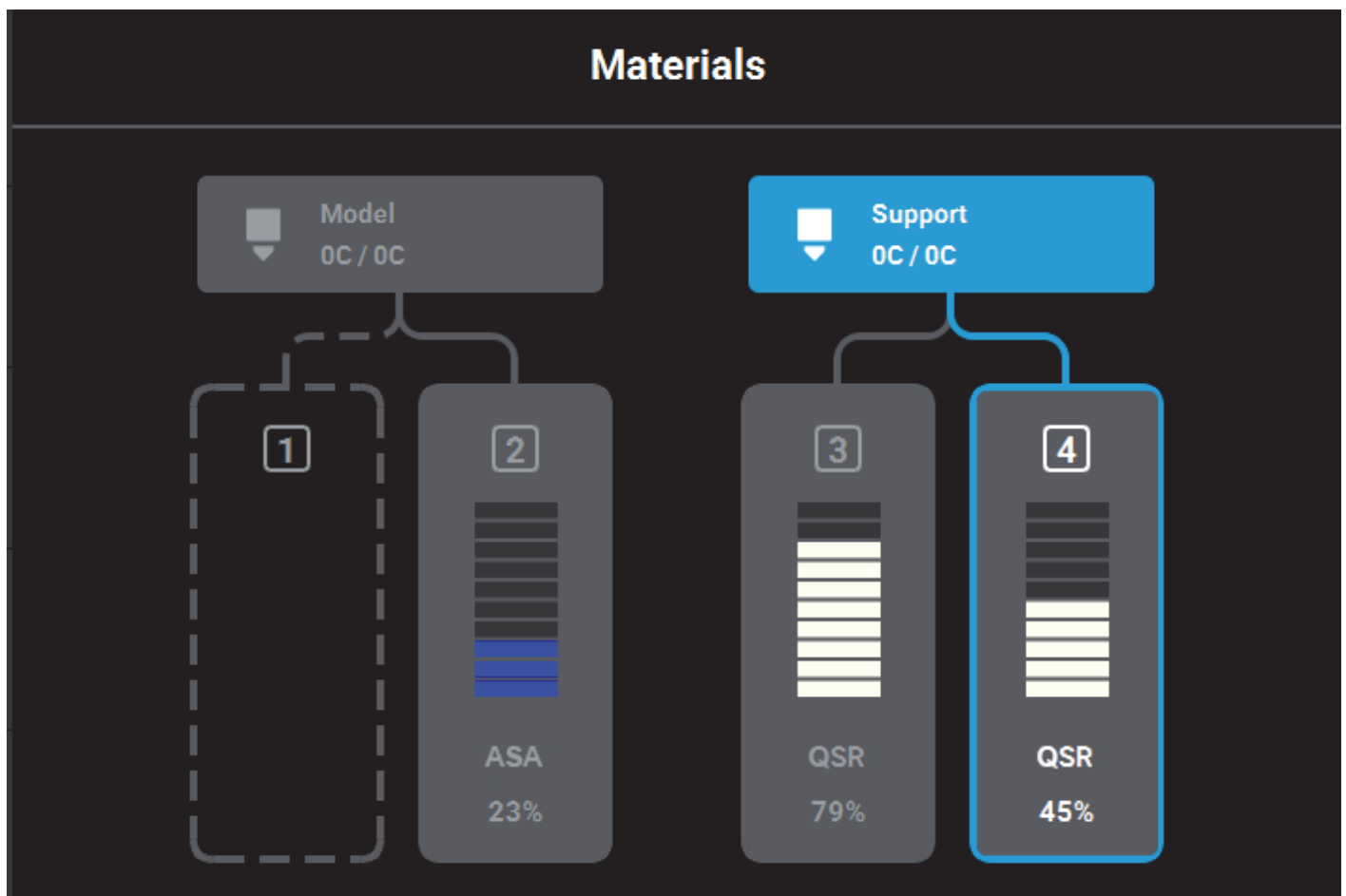

4. Open the material bay drawer.
5. Insert the material spool you'd like to load into its appropriate slot within the material bay.
 - Pull up on the latch securing the lid corresponding to the material bay you'd like to load, this will unlock the lid.
 - Open the lid to expose the slot where the material spool will be inserted.
 - Place the material spool into the slot making sure the filament tail is facing the back wall of the material bay.
 - Once the spool is inserted, the Material Status Icon will refresh and display a solid yellow border with a notification badge directly above the icon.

6. Open the Material Details page corresponding to the material bay for which you'd like to load material by touching its Material Status Icon on the screen.
7. Slowly turn the material spool and feed filament through the filament opening and into the drive mechanism. Turn the spool and feed filament until the Load button refreshes and is displayed in its selectable state.
 - Filament needs to be advanced approximately 2 inches (50.8 mm) to reach the filament present switch.
 - When feeding filament, ensure that filament does not fall over the edge of the material spool to avoid cross-winding and/or load errors.
 - The Material Status Icon will refresh and display in its solid gray unloaded state.

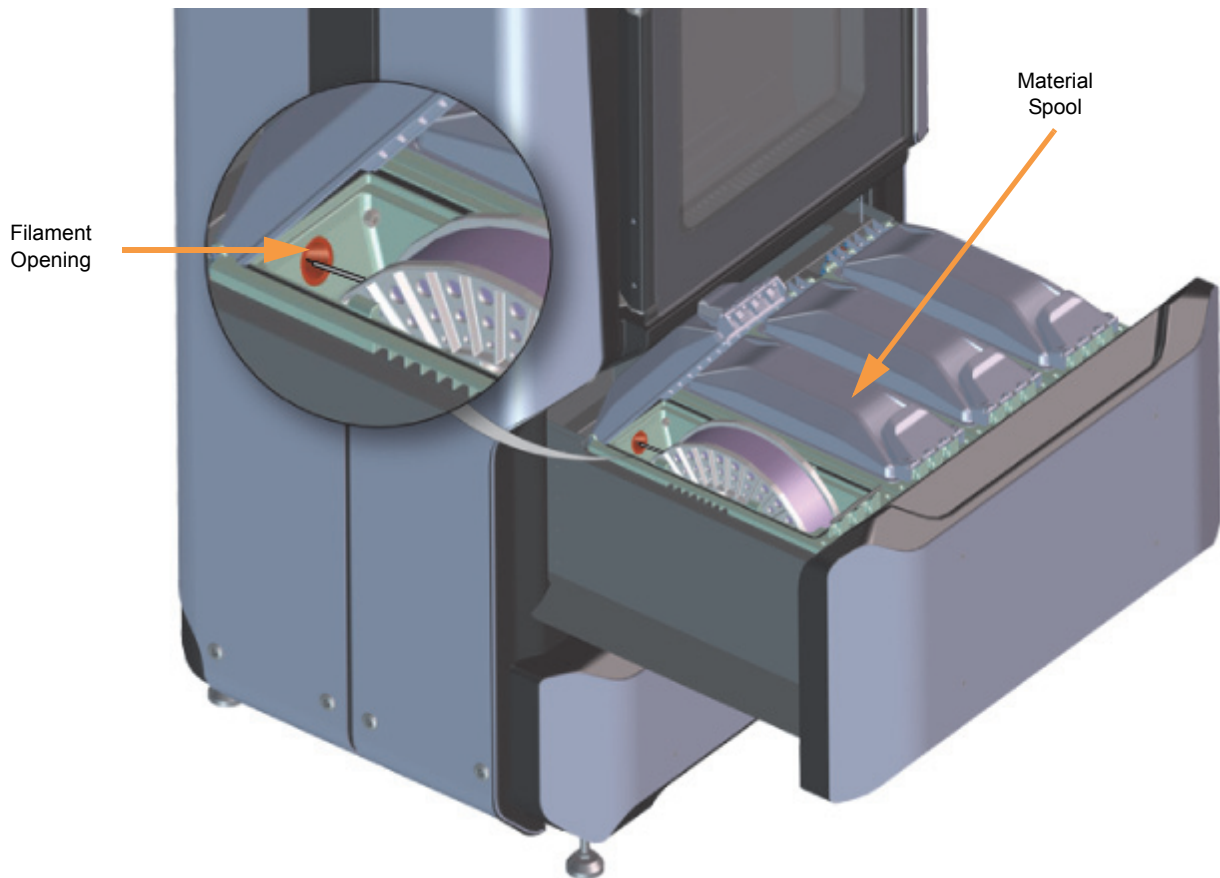

8. Once filament is detected by the filament present switch press the **Load** button within the Material Details page.



Note: Only one material can be loaded at a time.

9. Press the **Back** button within the Material Details page to exit and return to the Materials page.

10. Material begins to load to the liquefier tip within the head. The pathway displayed between the Material Status Icon and the corresponding Head Status Icon becomes highlighted to indicate load progress.
 - The material drive controller starts to push filament to the liquefier tip.
 - When filament reaches the head, it enters the liquefier tip and begins to warm to the material operating temperature (automatic - based on material spool memory chip data). This step also sets the oven temperature to the correct value for the material being loaded
 - Once the tip is within three degrees of the set point temperature the head moves to the purge area and the tip purges a small amount of material.
11. Once material is loaded, the filament pathway between the Material Status Icon and the corresponding Head Status Icon will be solid blue, the Head Status Icon will turn from gray to blue, and the Material Status Icon will display a solid blue border.
12. Once the material load is complete, close the lid corresponding to the loaded material bay and then close the material bay drawer.

You are now ready to select a job to build.

UNLOADING MATERIAL

Perform the following steps to unload material:

1. Ensure that the printer is stopped (idle) and is not building.
2. Select the **Materials** button from the Navigation Menu; a screen similar to following figure will be displayed. The information displayed represents the current configuration of your printer.
3. Observe the status information displayed for each of the Materials Status Icons. For a loaded material, the pathway between the material's Material Status Icon and corresponding Head Status Icon will be solid blue, the Head Status Icon will be blue, and the Material Status Icon will display a solid blue border.

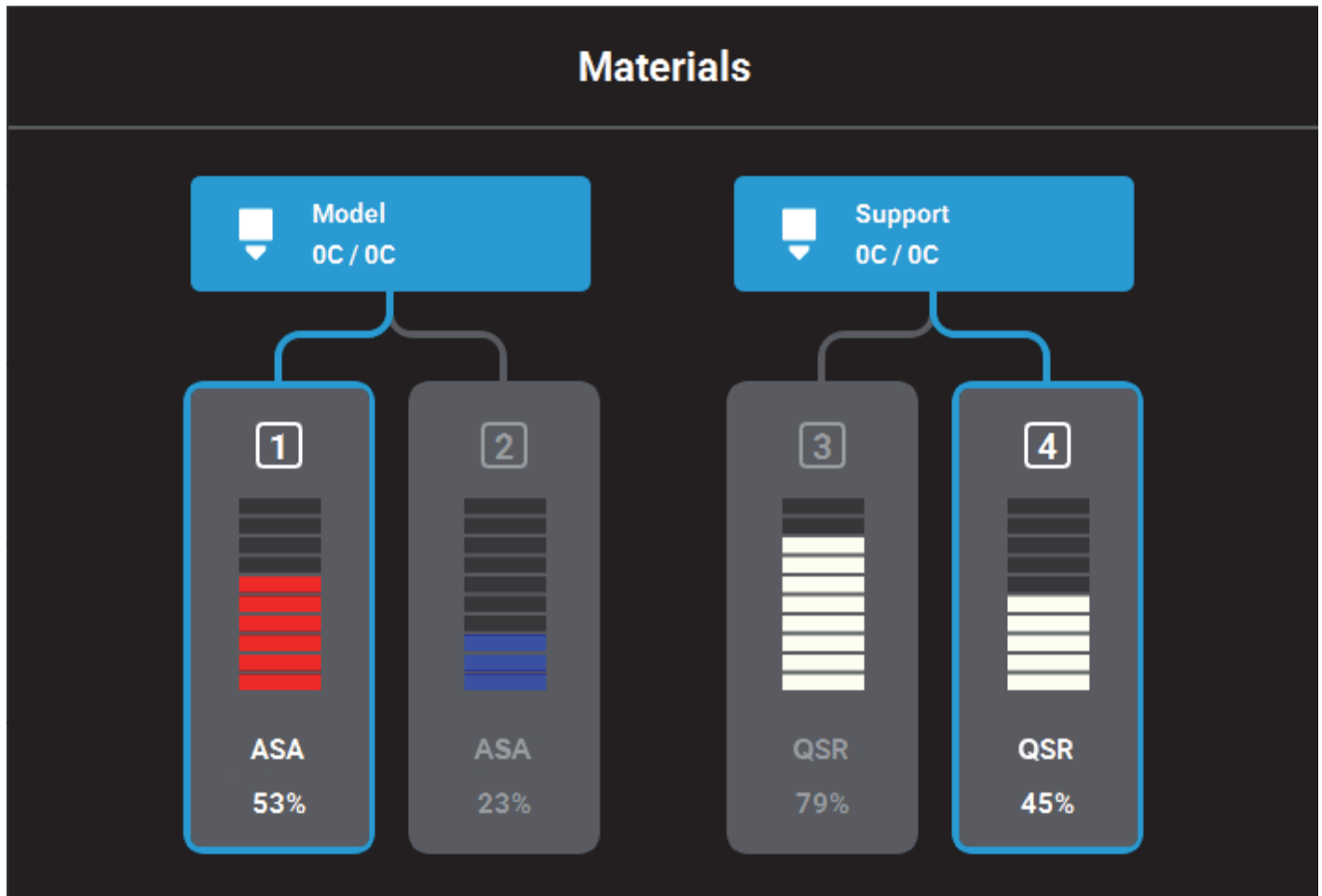

4. Open the Material Details page corresponding to the material bay you'd like to unload by touching its Material Status Icon on the screen.
5. Press the **Unload** button within the Material Details page.



Note: Only one material can be unloaded at a time.

6. Material begins to unload from the head. The unload process will take several minutes; please be patient.
 - The pathway displayed between the Material Status Icon and the corresponding Head Status Icon becomes highlighted to indicate unload progress.
 - The Head Status Icon will refresh and become solid gray, indicating that material is no longer loaded to the head.
 - The Material Status Icon will refresh and display a solid yellow border with a notification badge over the center of the icon. The icon will remain in this state until the material spool is reloaded or completely removed.

At this point you have the option of reloading the material spool you just unloaded or removing the material spool from the material bay.

REMOVING AN EMPTY MATERIAL SPOOL

1. Ensure that the material bay drawer is open.
2. Pull up on the latch securing the lid corresponding to the material bay containing the empty spool; open the lid to expose the empty material spool.
3. Lift the material spool out of its slot within the material bay. Once the material spool is removed from the material bay the Material Status Icon will refresh to display a dashed gray border, indicating that the corresponding material bay is empty.



Note: Empty spools may have a small, unusable volume of material remaining. The leftover material allows for manufacturing tolerances and ensures that auto changeover works properly.

4. There will be a piece of filament, approximately 2 inches (50.8 mm) in length that extends beyond the filament exit hole.
5. Discard the empty spool as it is no longer usable.

REMOVING A PARTIALLY USED MATERIAL SPOOL

1. Unload filament from the head.
2. Once unloaded, the material's Material Status Icon will display a solid yellow border with a notification badge over the center of the icon.
3. Ensure that the material bay drawer is open.
4. Pull up on the latch securing the lid corresponding to the material bay containing the material spool you'd like to remove; open the lid to expose the material spool.
5. Slowly turn the material spool to remove filament from the drive mechanism. Filament will be re-wound onto the spool. Turn the spool until the filament's tail exits the filament opening.



Note: When turning the spool ensure that filament is re-wound tightly onto the spool. If filament falls over the sides of the spool cross-winding can occur.

6. Lift the material spool out of its slot within the material bay. Once the material spool is removed from the material bay the Material Status Icon will refresh to display a dashed gray border, indicating that the corresponding material bay is empty.
7. Using the 5" cutters (included in the Welcome Kit) cut the filament so that the filament's tail is flush.
8. Snap the filament tail into place within one of the capture locations along the edge of the material spool.

9. Place the material spool into a storage bag (included in the Welcome Kit) and ensure that the bag is tightly sealed.
10. Install another material spool as needed.

MATERIAL AUTO CHANGEOVER

Auto changeover allows you to leave a long build unattended. When you know that a build will require more material than is available on a single material spool, you can pre-load the material from a second spool to utilize the auto changeover feature. Auto changeover is available on the F270 and F370 models only.



Note: You must pre-load material from the auto changeover material spool prior to auto changeover occurring (i.e. the spool's Material Status Icon must be in the unloaded state, and exhibit a solid gray border). If material is not pre-loaded, auto changeover will not occur and the printer will pause.

When an active material spool becomes empty:

1. The printer is paused and the drive motor automatically withdraws residual material from the printer.
2. Material from the changeover material spool is loaded to the head. The job is automatically resumed.



Note: If the material to be loaded is not the same as the material it is replacing, a material mis-match load error will occur. Auto changeover will not occur and the printer will pause.

3. While the changeover is taking place, the User Interface will update and indicate that this process is occurring. No user interaction is required.
4. If you press the **Pause** button during an auto changeover, the printer will remain paused after the changeover is complete.
 - After pressing the Pause button, the User Interface will update to indicate the reason for the pause condition.
 - Press **Accept** within the dialog on the screen to return to the Build page.
 - From the Build page, press the **Play** button to resume building.
5. If an error occurs during the auto changeover process, the printer will remain paused.
 - Navigate to the Materials page by pressing the **Materials** button within the Navigation Menu.
 - Observe the load status for each material. The Material Status Icon corresponding to the material spool experiencing the load error will display a red border. A notification badge icon within the filament pathway will also be displayed; press this icon on the screen to open the corresponding material's Material Details page.
 - Within the Material Details page text will be displayed indicating the cause of the load error. Touching this text on the screen may display a dialog with additional information pertaining to the error.
 - Once the error is resolved, return to the Build page.
 - Press the **Play** button to resume building or press the **Abort** button to cancel the build.

STORING MATERIALS

Stratasys FDM thermoplastic materials will maintain proper product performance over an extended period of time, when handled and stored according to recommended procedures. Like other thermoplastics, the filament can absorb moisture when exposed to ambient humidity. Stratasys material spools are designed to minimize moisture exposure while unopened and opened. When a spool's filament absorbs moisture a finished part's surface quality, seam quality, and overall part aesthetics can be affected. Care should be taken to ensure filament remains dry.



Caution: Material storage shall be in the range of 55°F to 86°F (13°C to 30°C), with relative humidity less than 70%.

Two model material spool sizes are available. Standard model material spools hold 60 in³ (984 cc) of filament while large spools hold 90 in³ (1475 cc). One support material spool size is available. Support material spools hold 60 in³ (984 cc) of filament.



Caution: A material spool should not remain outside of a sealed container for longer than 1 minute. A foil bag or a material bay are examples of acceptable containers.

Material spools also contain desiccant material; the desiccant is designed to maintain proper moisture levels for an unopened spool. Once the desiccant is exposed to ambient air, it can become saturated and ineffective for moisture control. Proper handling of the spool after it has been opened is essential to maximizing material life. A plastic bag provides an airtight seal to keep moisture from entering the material spool while stored.

If a material spool with material remaining on the spool is removed from the printer, it should be stored within one of the airtight bags provided within the Welcome Kit. Prior to placing the material spool into the bag, ensure that the spool's filament is securely snapped into place within one of the filament tail capture locations on the edge of the spool.

CHANGING HEADS

When a head reaches 1500 build hours (odometer limit), a warning will be displayed on the User Interface and the head's Head Status Icon will be highlighted in red on the Materials page. You can continue using a head which has exceeded its odometer limit, but it is highly recommended that you change the head as part quality will be unpredictable.

REPLACING A STANDARD HEAD

The information within this section is meant to guide you through the process of changing a standard head. Although the instructions below depict the replacement of the model head, the same procedure applies to both the model and support head. The process for replacing a PLA head varies slightly from the process for replacing a standard head.

1. Unload material from the head that will be replaced.
2. With the printer powered ON, open the top cover.



Note: Replacing a head while the printer is powered ON will ensure that an Automatic Tip Calibration is performed after the replacement process is complete.

Power is automatically removed from the head and all motors when the top cover is opened.

3. Depress the release tab and unclip the head ribbon cable for the head that will be replaced (model head is on the left, support head is on the right).
4. Disconnect the material tube for the head that will be replaced.
5. Unlock the head release lever for the head that will be replaced.

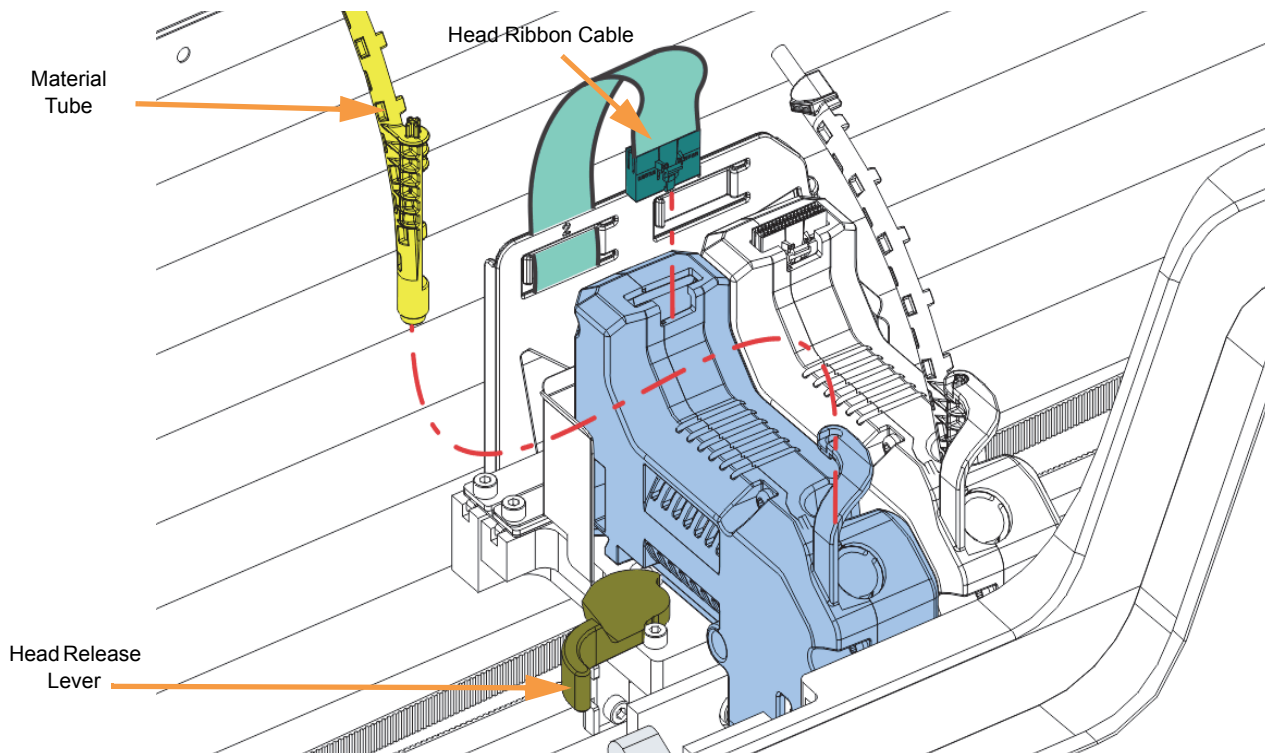

- Pull the head assembly out of its position within the gantry and remove it from the printer.

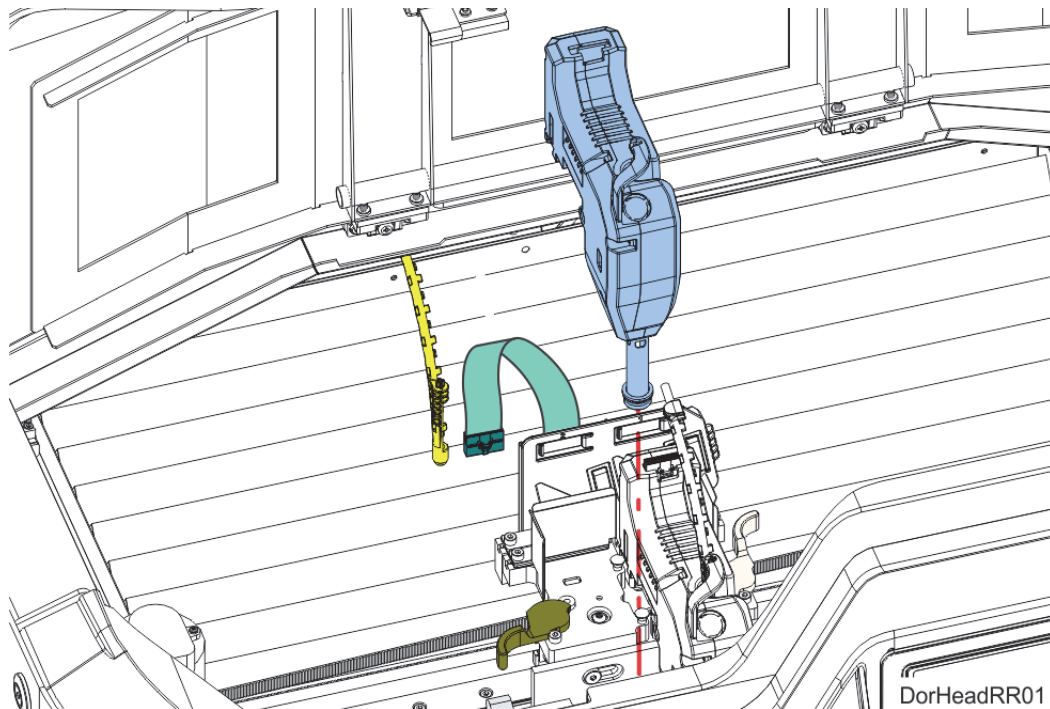

- Insert a new head assembly into the vacant location within the printer.
- Lock the head into place using the head release lever. Press the lever securely closed to ensure that the head is properly seated.
- Connect the material tube to the new head assembly.
- Insert the head ribbon cable connector into the new head assembly ensuring it is fully seated in the head and the connector retention latch engages.
- Close the top cover.
- An Automatic Tip Calibration will automatically be performed prior to the start of the next build following a head replacement. Please note that the printer must be powered ON before calibration can occur.



Note: If a head was replaced while the printer was powered OFF, an Automatic Tip Calibration does not occur after closing the top cover, you must manually initiate the calibration.

REPLACING A PLA HEAD

The process for replacing a PLA head varies slightly from the process for replacing a standard head. The PLA head must be installed into the model head location within the gantry. A cooling module is used in conjunction with the PLA model head and must be installed into the support head location. The PLA head extrudes both model and support structures.

To replace a PLA head or the associated cooling module, perform steps 1 - 11 above. Automatic Tip Calibration is not performed during PLA head replacement. When performing steps 3 and 7 remember that the PLA head must be installed into the model head location (on the left) and the cooling module must be installed into the support head location (on the right).

TIP CALIBRATION

Tip offset values are the distance between the model and support tips in the X, Y and Z directions. Accurate tip offset values ensure that support toolpaths are accurately located in reference to model toolpaths. Inaccurate tip offset values can cause part quality issues, such as support material embedded in a part or improperly supported parts.

The automatic tip calibration registers the support tip relative to the model tip. Auto-calibration is triggered any time the ribbon cables are disconnected from the printer heads while the printer is powered ON. The calibration will occur immediately prior to building the next part. You cannot build parts on the printer until the printer's tips are calibrated.

Automatic tip calibration can also be initiated from the touchscreen using the following procedure.

Performing Automatic Tip Calibration

1. Place a new substrate onto the platen and lock the substrate into its build position by lifting up on the substrate ejection handle.
2. From the touchscreen, navigate to **Tools > Calibration**. The printer's calibration status will be displayed within the Tip Calibration row. Calibrated or Not Calibrated will be displayed depending on the printer's current calibration status.
3. Press anywhere within the Tip Calibration row to display the Tip Calibration page.



4. The Tip Calibration page contains an option for performing an Automatic Tip Calibration as well as a Manual Tip Calibration. Press the designated **Start** button to initiate the Automatic Tip Calibration.

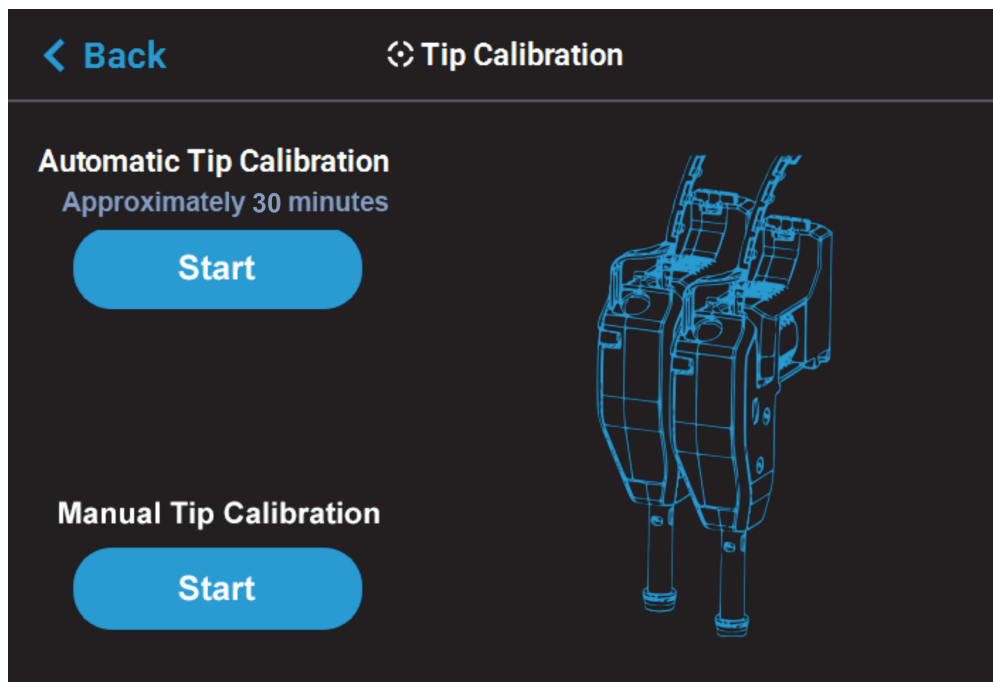

- The printer will perform an Automatic Tip Calibration. This process includes heating up or cooling down the oven to reach the required calibration temperature. Completion times will vary depending on the material used and the initial chamber temperature. The status and time remaining will continually update on the screen.

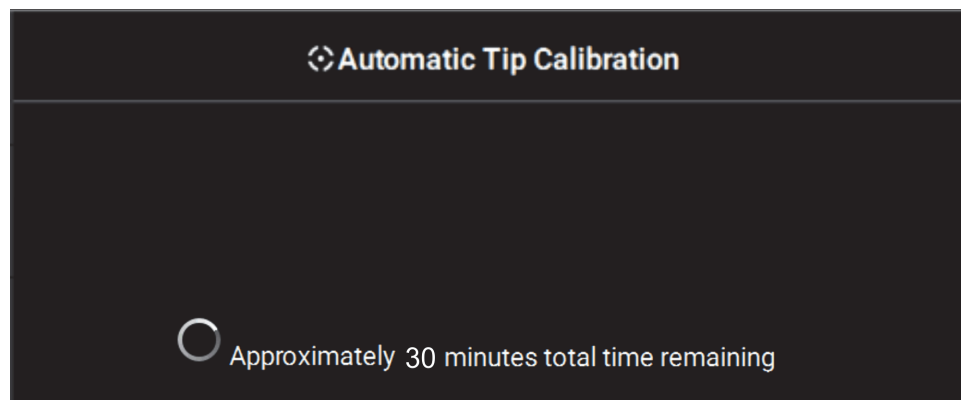
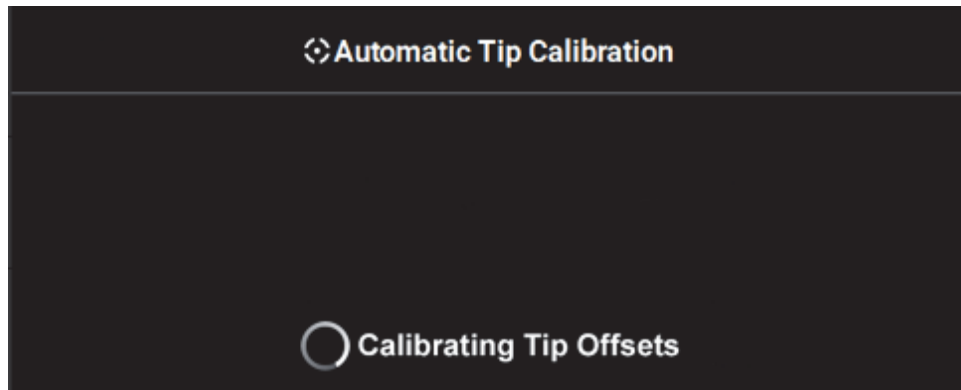

- Completion of the calibration process will be indicated on the screen; press the **Finish** button within the header of the page when complete.



Note: If calibration fails, "Failed to calibrate tip offsets" will be displayed on the screen. You cannot build a part on the printer until the tips have been calibrated. Ensure that nothing is blocking the tip or covering the calibration targets and reattempt the Automatic Tip Calibration.

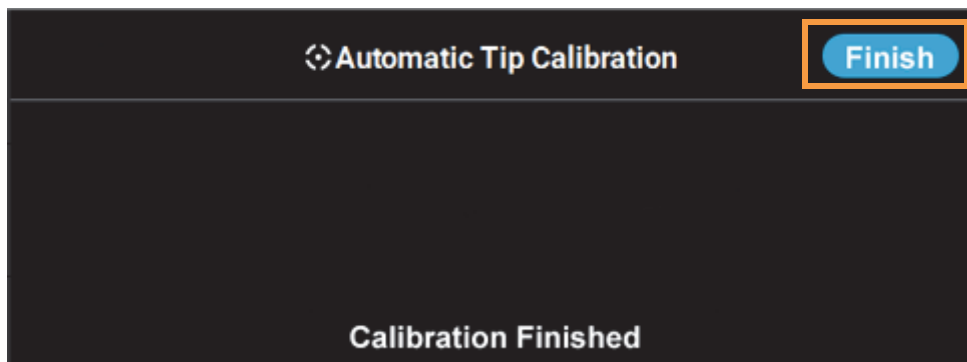

BASIC JOB BUILD TASKS

BEFORE A BUILD

To build a job, you must first download job files to the printer and then load individual job files to the Job Queue using one of two methods:

1. Network transfer via the GrabCAD Print application on your workstation PC. This is the preferred method for adding jobs to the Job Queue.
2. USB method via a USB flash drive inserted into one of the available USB ports.

The GrabCAD Print option allows you to select a job which was processed and sent to the printer (via your facility's Ethernet connection or via Wi-Fi) using the GrabCAD Print application on your workstation PC. Jobs are sent in CMB format and placed directly into the Job Queue (stored on the printer's hard drive). The CMB file contains the processed job's basic information; this information is used to verify job compatibility with the printer's existing configuration. For information on using GrabCAD Print, see the associated Help file within the GrabCAD Print application.

The USB option allows you to select a job file which is stored on a USB flash drive inserted into one of the available USB ports. This method can be used as a backup to the GrabCAD Print method if you are unable to transfer job files to the printer via your network connection (due to poor connectivity, a network outage, etc.) and provides a convenient option for you to reprint a common job. Alternatively, you have the option of selecting a single job file off of a USB flash drive and printing it directly within the Build page. This option is only available if the Job Queue is empty.

PREPARING THE PRINTER

To prepare the printer for a build:

1. Power ON the printer.



Warning: Wear proper safety equipment when handling items inside the oven as surfaces within the oven can be very hot.

2. Open the oven door.
3. Place a new substrate onto the platen and lock the substrate into its build position by lifting up on the substrate ejection handle.



Note: Never print in the same location more than once on a substrate when building a job.

Using substrates not provided by Stratasys may impact part quality and printer reliability.

4. Make sure that the tip wipe assembly's brushes as well as the printer's tips are clean and that the purge area is free of purged material debris.

SELECTING A JOB TO BUILD

1. Populate the Job Queue.
2. Select the **Queue** button within the Navigation Menu; the Queue page will open to display the Job Queue.
3. Within the Job Queue list, locate the job you'd like to build and select it by touching its row on the screen; doing so will open its Job Details page.



Note: Jobs are built in the order in which they appear within the Job Queue. To build a specific job, that job must be listed as the first item in the Job Queue. Use the Job Queue Control buttons to sort job files as needed.

4. Within the Job Details page press the **Print** button; this will queue the job for printing. Depending on your printer's part placement setting configuration a dialog may be displayed.
 - If the Enable Part Placement setting is set to Off (default setting), a dialog will not be displayed and the job will automatically be built in the center of the substrate.
 - If you set the Enable Part Placement setting to On, a dialog will be displayed allowing you to select the job's build location. The dialog contains a graphic representing your printer's platen as well as a blue bounding box graphic (the imaginary box surrounding the part). Select the job's build location by dragging and dropping the bounding box on the touchscreen. When finished, press the **Print** button within the dialog to confirm your selected placement and start the build.
5. The Build page will open and the oven will begin to heat to a set point temperature determined by the material types specified for the job. Please be patient.
6. After the oven and liquefier tips reach temperature the printer performs a Z Zero Calibration. "PREPARING" is displayed within the Build Status Display while this calibration occurs.
7. Once Z Zero Calibration is complete the printer begins building the job. "BUILDING" is displayed within the Build Status Display as the part is being built.
8. When finished, text is displayed on the touchscreen indicating that the completed part can be removed from the printer.

INFORMATION AVAILABLE DURING A BUILD

During a build, information pertaining to that build is displayed within two areas of the Build page:

The Print Job Information Panel displays the details of a job, as submitted to the printer from the workstation PC. This information is static and is for reference purposes only.

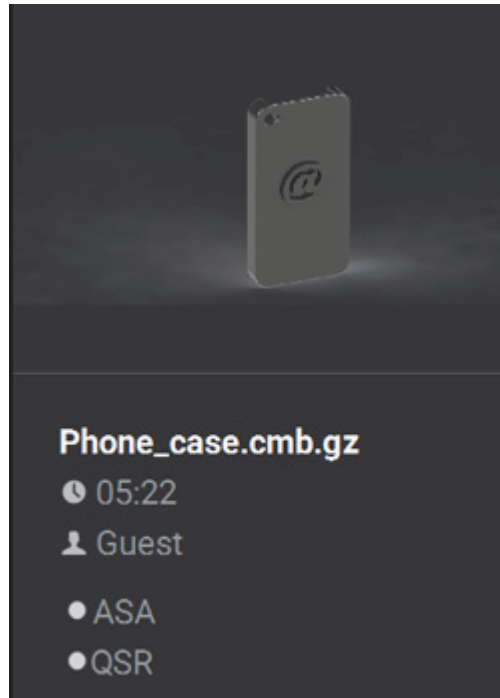

Information displayed within this panel for a selected job includes:

- Name of the job.
- Estimated build time for the job.
- Name of the user that submitted the job.
- Model and support materials associated with the job.

The Build Status Display section of the Build page is composed of a two-part graphic which provides information on a building job. See [“Build Status Display” on page 46](#) for detailed information.

- The Build Status Information portion of this graphic provides information on a selected and/or building job. Text pertaining to the current status of the build is displayed within the upper portion of the graphic, while the amount of build time remaining is displayed within the lower portion of the graphic.
- The outer Build Progress Ring corresponds with the build information displayed. As build progress is made, the build’s percentage of completion is also displayed by radially filling in the outer progress ring, in blue, in a clockwise direction.
- Touching the screen within the center of the Build Status Display while a part is being built will toggle the information displayed. After touching the screen the time estimation information will be hidden from view and instead the Build Status Display will show the number of completed layers as compared to the total number of layers in the build. Touching the screen again, will toggle back to the time estimation information displayed initially.

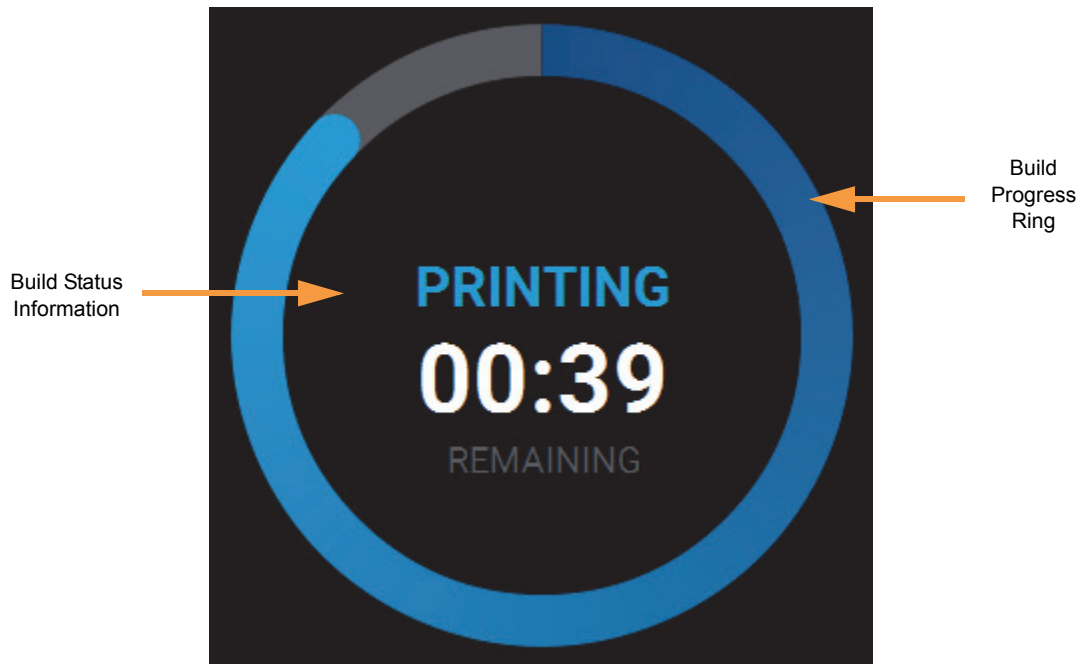

BUILD WARNINGS

If the printer detects an issue that may affect a build, it will be indicated within the Notifications Display portion of the Build Page. A yellow or red notification badge icon will be displayed, depending on the severity of the warning/error, along with text indicating the reason(s) for the warning. Touching the text on the screen will open a dialog indicating the reason(s) for the notification, and in some cases, steps to correct the notification.

Depending on the type of warning, a notification badge icon may also be displayed within the Material Status Icons of the Materials Page. Touching the notification badge icon on the screen will open the corresponding material's Materials Details page and provide information indicating the cause of a warning/error.

- When loading and unloading materials you may encounter load related warnings which need to be resolved prior to starting a build.
- When starting a build you may encounter a variety of warnings pertaining to the printer's current materials configuration. If the printer has not been calibrated, the materials installed within the printer do not match the requirements of the build, or the printer does not contain enough material to complete the build, you will receive a warning instructing you to resolve this issue.



Note: You can choose to ignore the warning and continue the build, but part build quality will be unpredictable. A warning generated from a mis-match of model/support material cannot be bypassed.

- In some cases, the warning will prevent you from starting a build and will need to be corrected before the printer can build a part.
- While the printer is building, various pause and abort related warnings may be displayed. Some of these warnings may be due to a manual pause or abort, while others may be the result of the printer automatically pausing or aborting a build. Depending on the severity of the warning you may or may not be able to resume building.

PAUSING A BUILD

During a build the Pause button within the Build page becomes selectable. The printer can pause automatically, or be manually paused using this button:

- An automatic pause occurs when a material spool runs out of material, a failure is detected, etc.
- A manual pause occurs whenever the **Pause** button is pressed.

When the printer is directed to pause:

1. The current toolpath is completed, the Z stage is lowered slightly, and then the head assembly is parked. "PAUSED" is displayed within the Build Status Display.
 - If an automatic pause occurs, text will be displayed within the Notifications Display portion of the Build Page. Touching the text on the screen will open a dialog indicating the reason for the pause condition (i.e. empty material spool). Correct this condition and then press the **Close** button to exit the dialog.
2. The Pause button will toggle and instead display the Play button. To resume building, press the **Play** button. A resume command will be sent to the printer instructing it to resume the build.



Note: The printer will not resume building instantaneously, please be patient.

If the oven door is open the part will not resume building immediately. Touch the text displayed within the Notifications Display portion of the Build page to check for any errors in order to troubleshoot this situation.

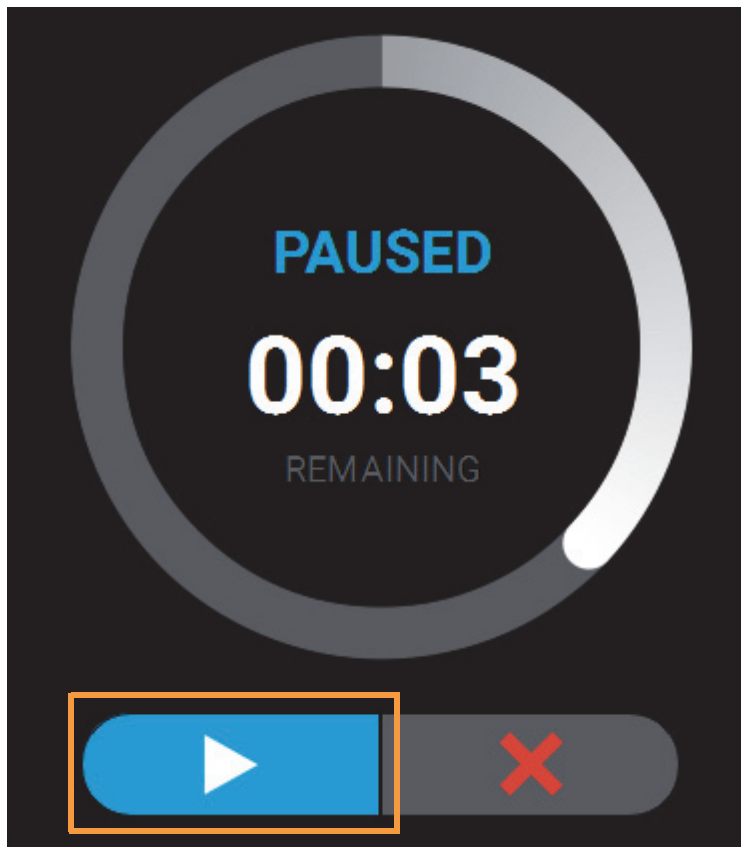

3. Once the build resumes, "BUILDING" will be displayed within the Build Status Display and the Pause button will be displayed in its unselected state.

ABORTING A BUILD

When the printer is building, you have the option of directly aborting the build. To do so:

1. The Abort button within the Build page will be selectable, press the **Abort** button.
2. A dialog will be displayed allowing you to confirm or cancel the abort; press the **Accept** button within the dialog to confirm the abort.

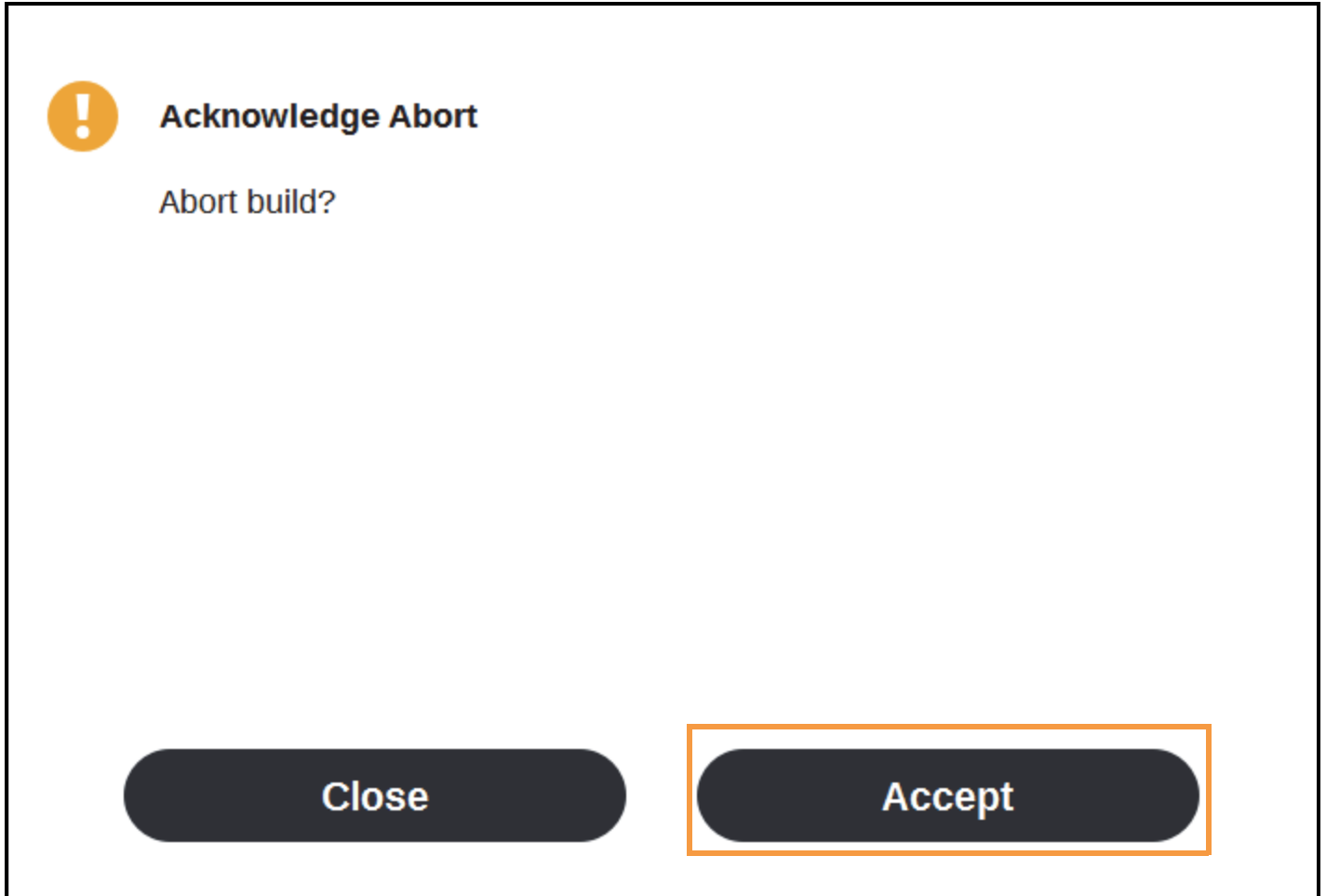

3. An abort command will be sent to the printer and the confirmation dialog will close.
4. The Z stage will move to its end of travel. Once the Z stage reaches its end of travel the Build page will refresh and display a confirmation of the aborted build; "CANCELLED" will be displayed within the Build Status Display.
5. The Print Job Control buttons will be hidden and instead "Print aborted" will be displayed within this portion of the Build page. Touching this text on the screen will open a dialog with instructions on how to remove the aborted build and prepare for your next build.

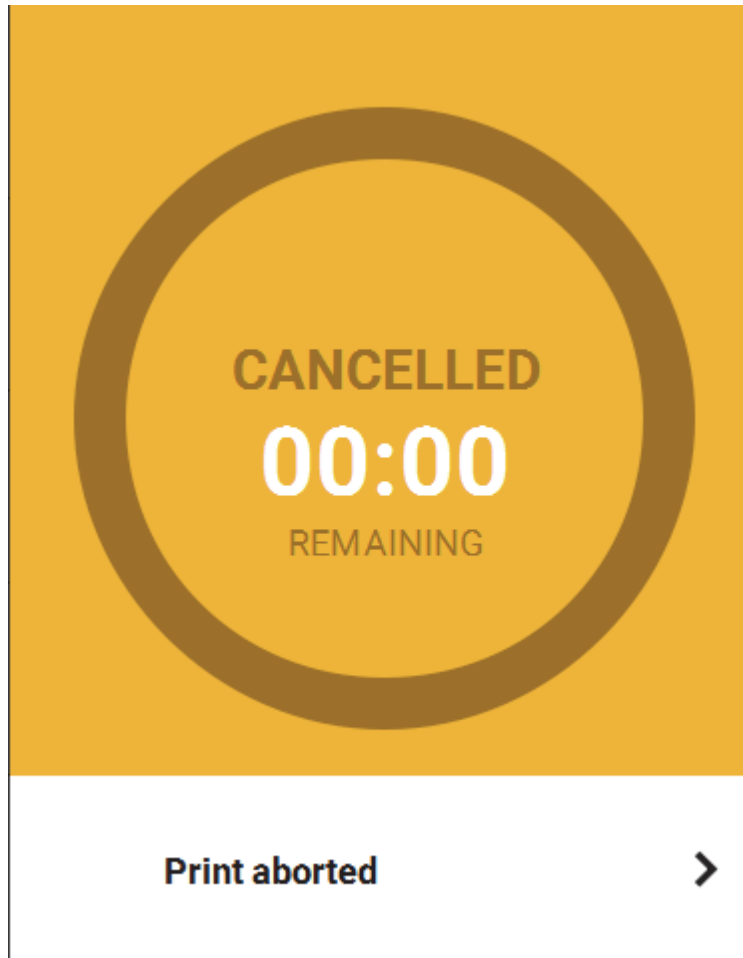

AFTER A BUILD IS COMPLETE

After the completion of a build, the printer performs the following actions:

- The Z stage is lowered and the head assembly is parked.
- "DONE" is displayed within the Build Status Display.
- The Print Job Control buttons will be hidden and instead "Print successful" will be displayed within this portion of the Build page. Touching this text on the screen will open a dialog with instructions on how to prepare for your next build.
- The Build button will display a green checkmark icon indicating that the build completed successfully.



Note: If the build was terminated abnormally, a warning indicator will be displayed on the screen.

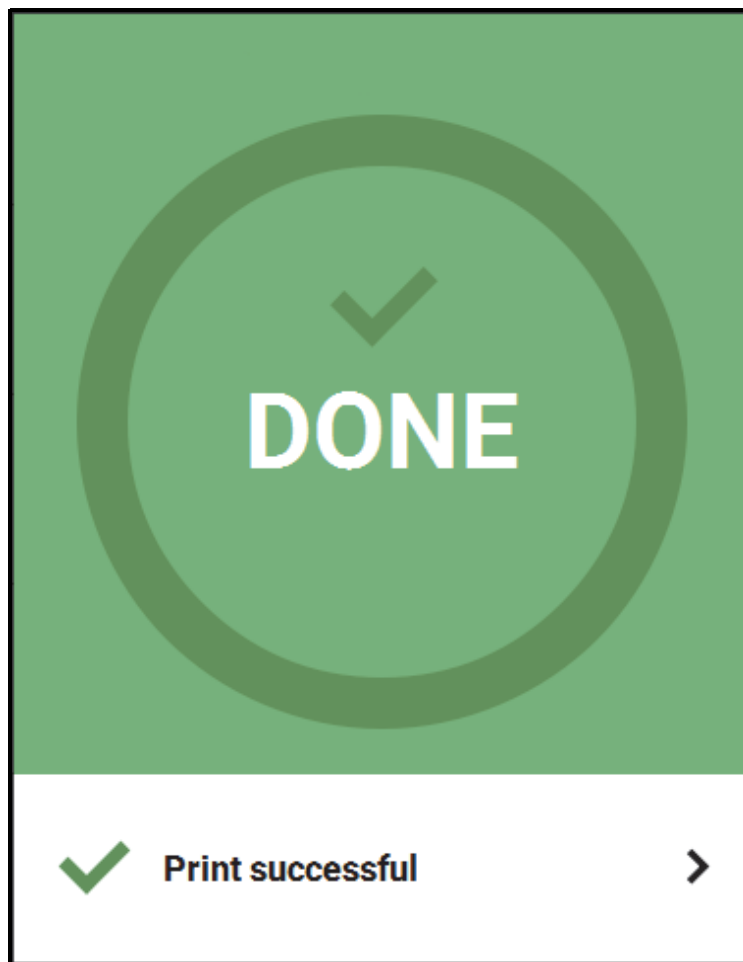

REMOVING A PART FROM THE PRINTER



Warning: Wear proper safety equipment when handling items inside the oven as surfaces within the oven can be very hot.

To remove a part from the printer:

1. Open the oven door.
2. Push down on the substrate ejection handle to release the substrate.



Caution: Do not attempt to remove a part from the substrate while the substrate is on the platen. Damage to the platen or platen level may occur.

3. Remove the substrate from the platen.
4. Carefully remove the part from the substrate.

USER MAINTENANCE



Warning: Always wear proper heat protective clothing when working inside the oven.

Maintenance tasks must be performed on a regular basis in order to maintain optimal system operation. The Maintenance Schedule table outlines the general maintenance schedule for the F123 Series. Detailed instructions for each task make up the rest of this chapter.

The Replacement Consumables table lists part numbers for various replacement consumable items. Use the part numbers listed in this table when ordering replacement parts from Stratasys or your regional Stratasys office.

Maintenance Schedule

Weekly	Monthly	As Needed	Maintenance Task
X			Clean the oven chamber
X	X		Clean the platen
		X	Clean/Inspect the tip wipe assemblies
		X	Clean the exterior surface of the printer
		X	Clean the touchscreen display

Replacement Consumables

Part Number	Description
123-00300	Model Head (standard)
123-00300	Support Head (standard)
123-00307	PLA Model Head
123-00301	PLA Cooling Module
123-00302	F170 substrate 1 box of 16
123-00303	F270 substrate 1 box of 16
123-00304	F370 substrate 1 box of 16
123-00305	Tip shield kit - 4 sets
123-00306	2-pack of tip wipe assemblies.

WEEKLY MAINTENANCE

CLEANING THE OVEN CHAMBER



Warning: Always wear safety gloves and long sleeves when cleaning the oven chamber. Components are hot and may have sharp edges.

The purge chute is designed to guide purged material debris from the tip wipe assemblies to the bottom of the oven chamber for disposal. Purged material debris then collects within the bottom of the oven chamber, beneath the platen. Do not allow excess material debris to accumulate in the oven chamber as this could cause damage to the printer. Clean the oven chamber on a weekly basis to remove build material debris and dust. A standard vacuum can be used to clean this area if needed. If excessive accumulation occurs vacuum the oven chamber as needed.

CLEANING THE PLATEN

The steel platen provides the level surface on which parts are built (see Figure 3-7 on page 26 for platen overview). A substrate is securely affixed to the platen by the substrate ejection handle. If debris collects on the platen, it can adversely affect substrate adhesion.

1. Remove the substrate from the platen.
 - Push down on the substrate ejection handle to release it from the platen.
 - Slide the substrate from the platen.
2. Carefully remove purged material debris that have fallen into the openings of the platen.
 - A standard vacuum can be used to clean the platen.

MONTHLY MAINTENANCE

CLEAN/INSPECT TIP WIPE ASSEMBLIES

The tip wipe assemblies should be cleaned once a month. While cleaning the assemblies, inspect the flicker/brush assemblies for wear and replace as necessary when wear is detected.

Once material is purged from a tip, the flicker portion of the tip wipe assembly passes across the tip's opening, cutting purged material off in small segments. The brush portion of the tip wipe assembly then passes across the tip's opening cleaning the tip and its tip shield. As a result, the flicker will wear at the location where the tip contacts its surface and eventually develop a notch large enough for the tip to completely pass through the flicker; a notched flicker cannot properly cut purging material. Similarly, material can become embedded within the bristles of the brush resulting in clumping; clumped bristles cannot properly clean a tip or its tip shield. The tip wipe assembly should be replaced once a significant notch develops within the flicker portion of the assembly or whenever bristle clumping (which cannot be removed with a brush) is apparent within the brush portion of the assembly. The tip wipe assembly is replaced as a single unit.

To clean the tip wipe assembly and inspect its components:

1. Ensure that the printer is stopped (idle) and is not building.
2. Open the oven door.



Hot Surface: Depending on how long the oven has been allowed to cool, components may be hot. Wear the safety gloves provided in the Welcome Kit to perform all remaining steps.

3. Remove the model side tip wipe assembly by lifting it upward until it clears its locating pins.

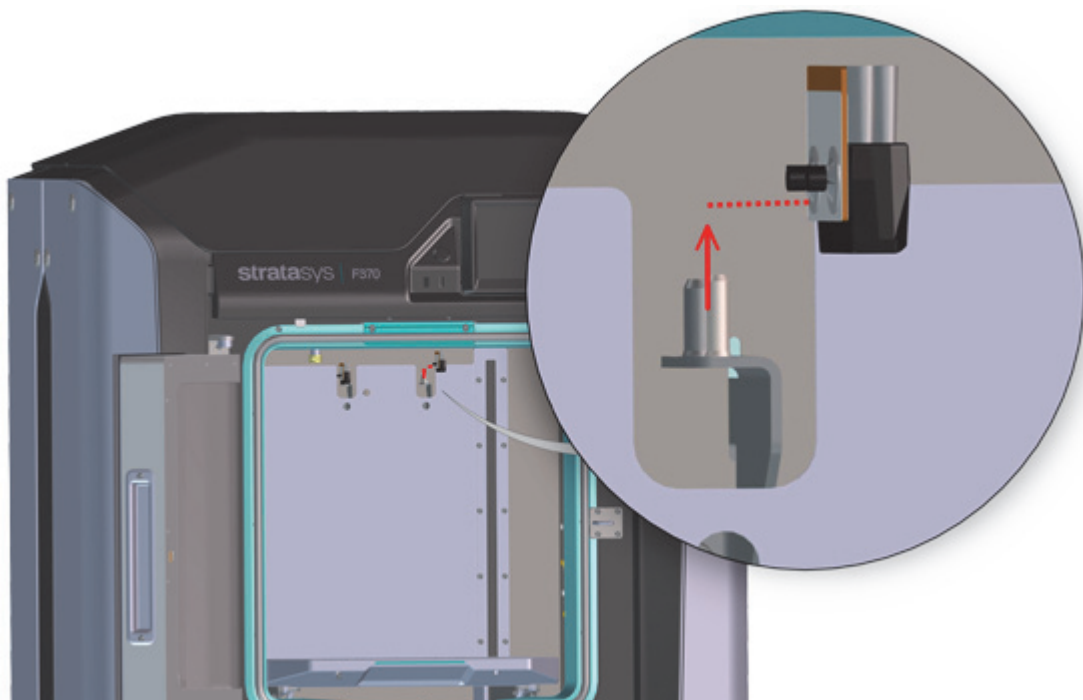

4. Repeat step 3 to remove the support side tip wipe assembly.



Note: If the head is positioned above the purge area it may impede your ability to remove the tip wipe assemblies. Open the top cover and manually move the head away from the purge area.

5. Clean and inspect the surface around the locating pins. Make sure that the tip wipe assemblies can sit flush on the surface.
6. Inspect the flicker portion of the tip wipe assemblies. The top edge of the flicker should be straight and must not contain excessive notching/wear.
7. Inspect the brush portion of the tip wipe assemblies. Brush bristles must not show evidence of wear (i.e. no notches in bristle pattern) and should not contain significant bristle clumping. Frayed bristles are acceptable as long as the top edge is even across all of the bristles.
8. Replace one or both of the tip wipe assemblies if excessive wear is present.
 - The components of the assembly cannot be replaced individually. The entire tip wipe assembly must be replaced if excessive wear is present on the flicker or the brush.

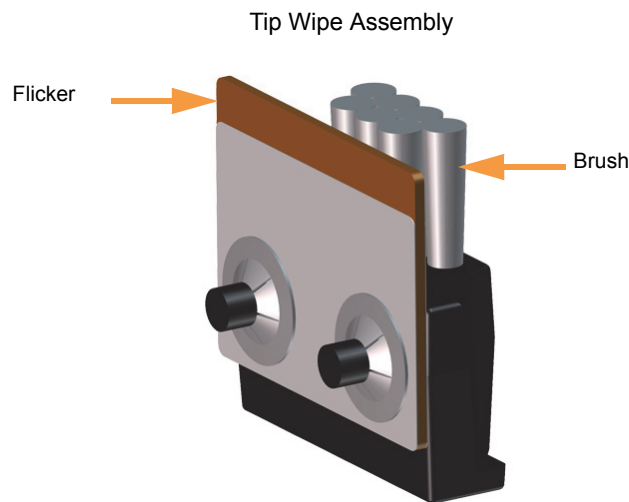

9. Reinstall the support side tip wipe assembly by placing the assembly onto its locating pins and sliding the assembly downward.
10. Repeat step 9 to reinstall the model side tip wipe assembly.

AS NEEDED MAINTENANCE

CLEANING THE EXTERIOR SURFACE OF THE PRINTER

The printer's exterior surfaces (doors and panels) may accumulate dust and periodically require cleaning. Exterior doors and panels, with the exception of the touchscreen display, can be cleaned using a slightly damp microfiber cloth (supplied in the Welcome Kit). The cloth should be only slightly damp to ensure that water does not enter the printer. Excess water can cause damage to interior components.

CLEANING THE TOUCHSCREEN DISPLAY



Caution: Using a cleaner which contains ammonia and/or alcohol can damage the touchscreen. Only a suitable LCD cleaning solution and microfiber cloth (included in the Welcome Kit) should be used to clean the touchscreen display.

As needed, to remove smudge marks and buildup, clean the touchscreen display using the LCD cleaner and microfiber cloth provided in the Welcome Kit.

Apply an adequate amount of LCD cleaning solution to the provided microfiber cloth and then gently wipe the exterior surface of the touchscreen display to clean its surface. It is recommended that you apply LCD cleaner to the microfiber cloth rather than applying cleaner directly to the touchscreen display, as excess moisture may damage the display.



HEADQUARTERS

7665 Commerce Way, Eden Prairie, MN 55344

+1 888 480 3548 (US Toll Free)

+1 952 937 3000 (Intl)

+1 952 937 0070 (Fax)

2 Holtzman St., Science Park, PO Box 2496

Rehovot 76124, Israel

+972 74 745-4000

+972 74 745 5000 (Fax)

ISO 9001:2008 Certified

For more information about Stratasys systems, materials, and applications contact your Stratasys representative or visit www.stratasys.com.

DOCUMENTATION FEEDBACK

Customers, resellers, and Stratasys employees are encouraged to send comments about our documentation and training to c-support@stratasys.com. We greatly value your comments, review all of them, and use them to improve subsequent releases of the documentation. In your email message please include the document title, part number (located on the front cover), and page number. Please note that we do not respond to general questions or support requests submitted to this email address.

stratasys

THE 3D PRINTING SOLUTIONS COMPANY